



P O R S C H E

ELECTRICITY = CLEAN ENERGY. BUT, WHERE DOES IT COME FROM?

84.3% OF GLOBAL ENERGY COMES FROM FOSSIL FUELS



FOSSIL FUELS
85%

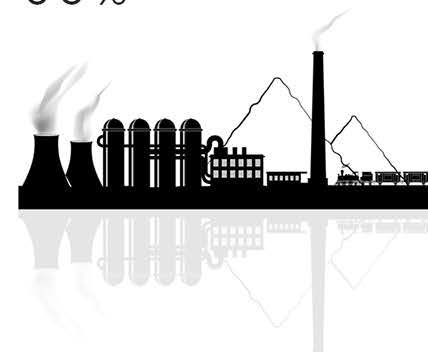

┌ AUTHENTIC FUTURE CLEAN ENERGY

SOLUTION / ENERGY ┐

_ W I N D P O W E R



CONSISTENT
RENEWABLE
SUSTAINABLE

GENUINE
FUTURE ENERGY SOURCE.

└

P O R S C H E ┐

THE MORE OUR TECHNOLOGY IS ADVANCED,
THE LESS WE GET REST AND SLEEP.



News

'Catastrophic' lack of sleep in modern society is killing us, warns leading sleep scientist

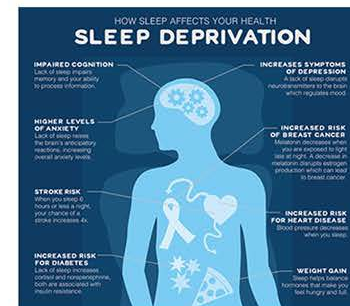

THE MOST OPTIMAL ENVIRONMENT FOR HUMAN CURE

_ ZERO GRAVITY



RE-COMFORT
RE-FRESH
RE-ENERGIZE

GENUINE
CURE SPACE FOR YOU.

IN

SOLUTION / HUMAN

_ HIBERNATION



P O R S C H E

A . C 200 P O R S C H E
S K Y A . I . W O R L D

AROUND THIS ERA, ALL THE TRAFIC SYSTEM IS BUILT ON THE SKY TO SOLVE VARIOUS KINDS OF TRAFIC PROBLEM
ON THE GROUND

LOS ANGELES
U . S . A



ZERO CABIN

WIND ENERGY

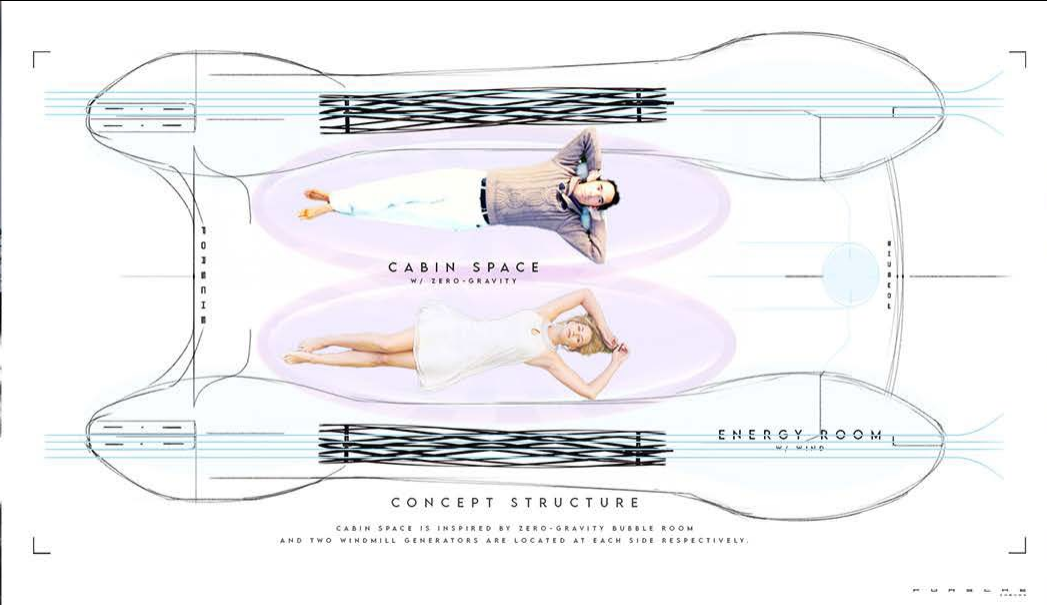

STARSHIP
STRUCTURE

INDEPENDENT CABIN

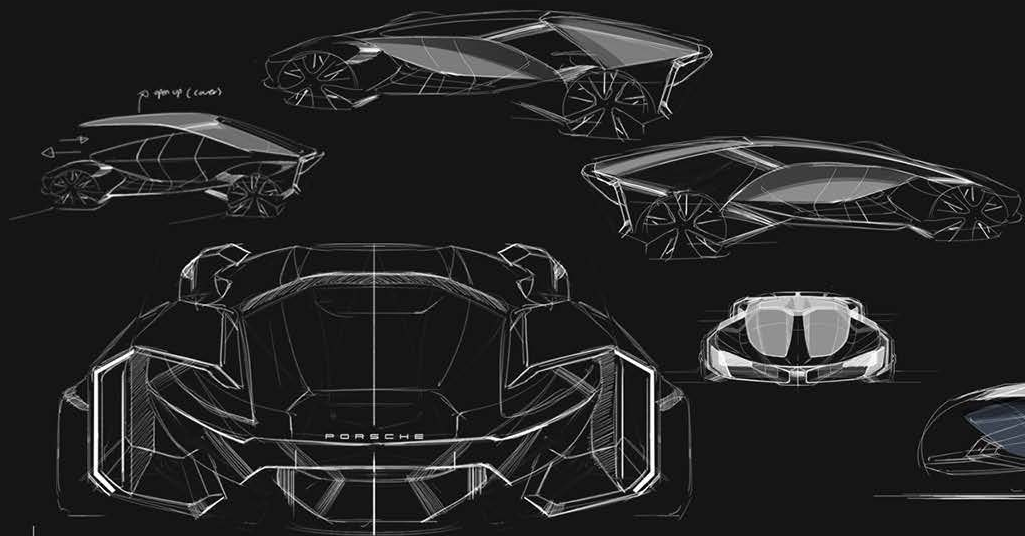

STRUCTURE IDEATION 1

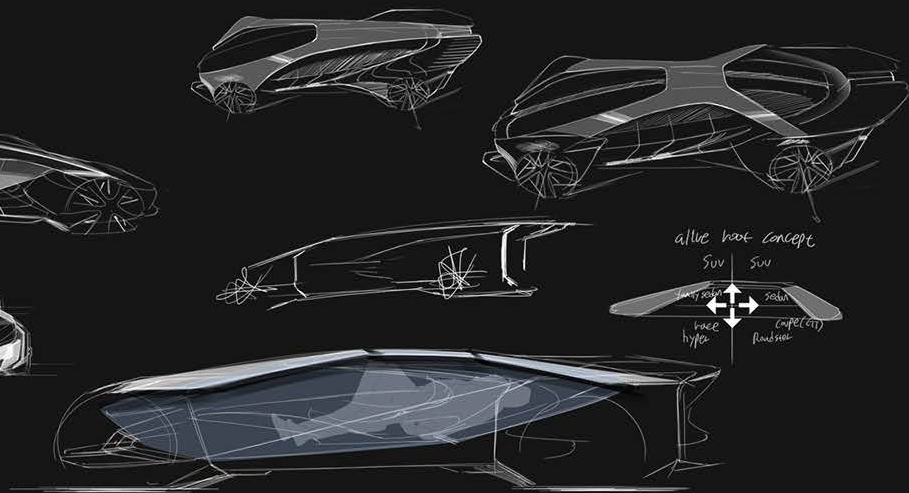

all the best concept
SUV SUV
imp. seat
base
hyla
Rads
cap (GT)
Rads

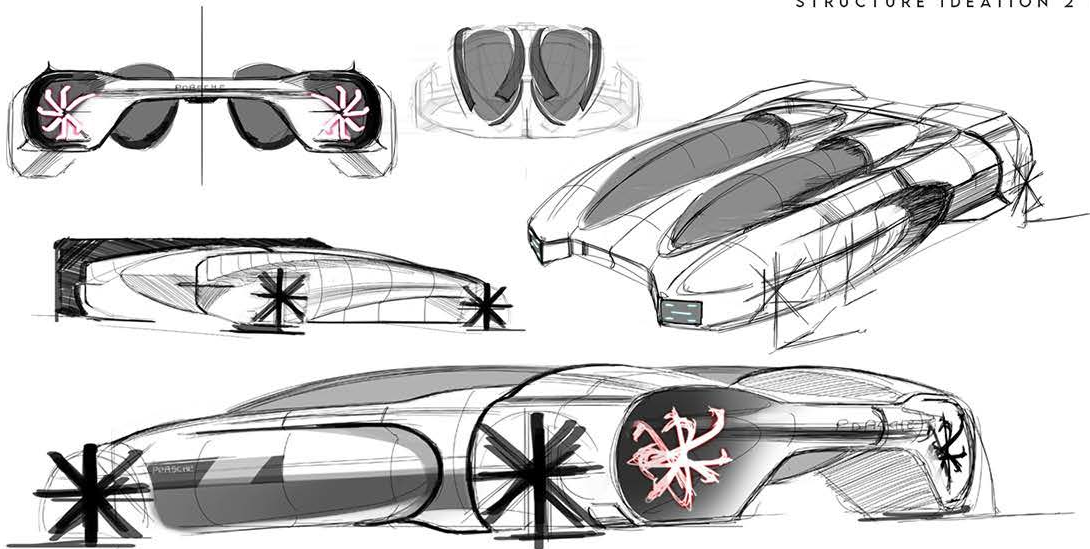
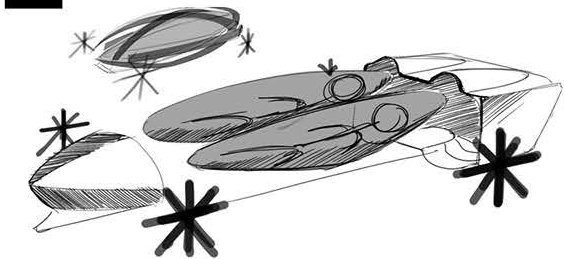

STRUCTURE EXPLORATION

STRUCTURE IDEATION 3
_ SUBMARINE

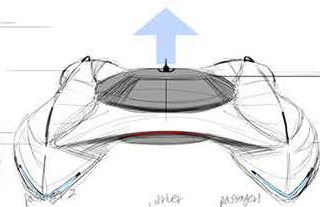
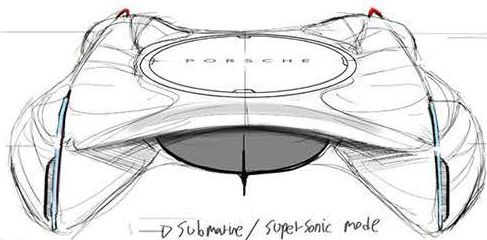

PANOPTICON
CABIN



CABIN

landscape / driving mode

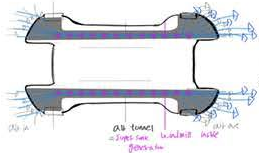
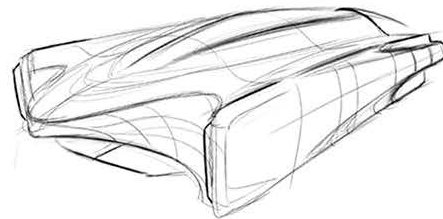

WINDMILL PROPELLER
INTO THE MODULE
WHEEL

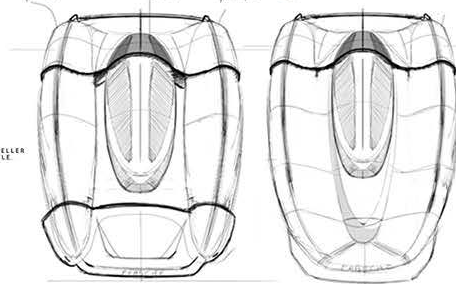

P O R S C H E
A M E N D E

STRUCTURE EXPLORATION

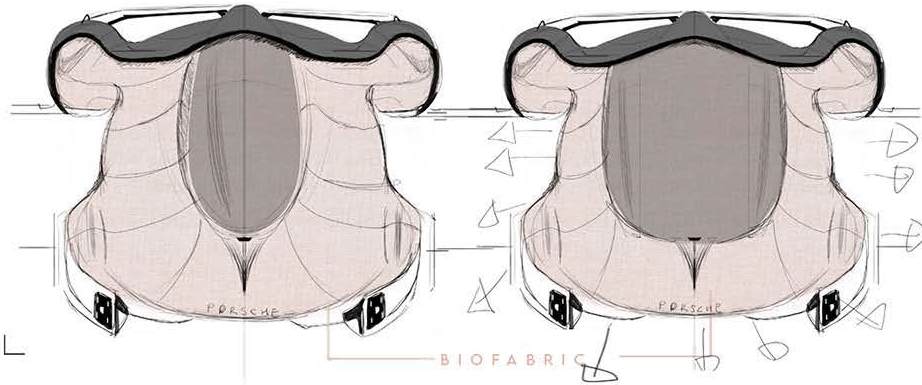

STRUCTURE IDEATION 4
_BIOFABRIC

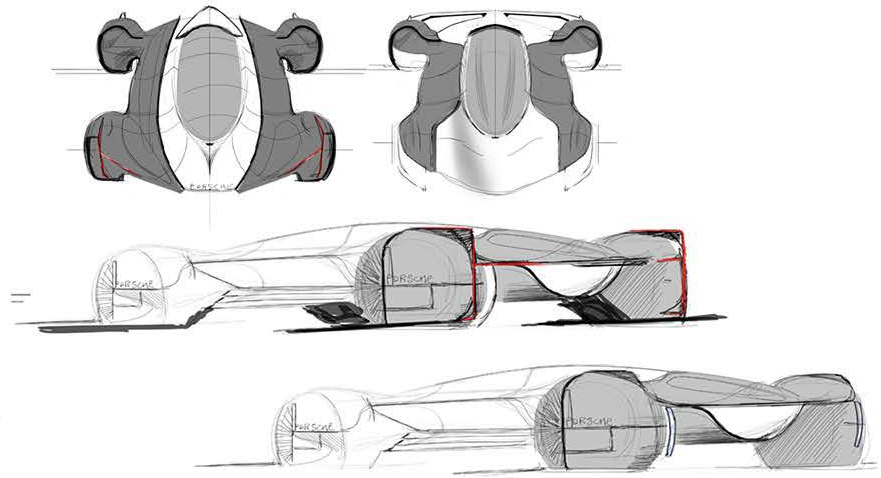

P O R S C H E
A M E R I C A

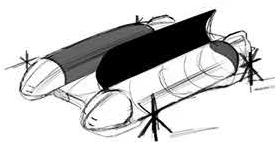
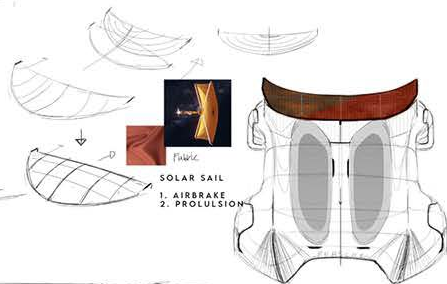
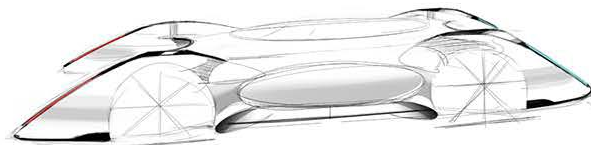
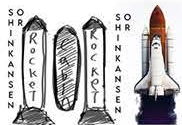

STRUCTURE IDEATION 4
_ STARSHIP & MONORAIL

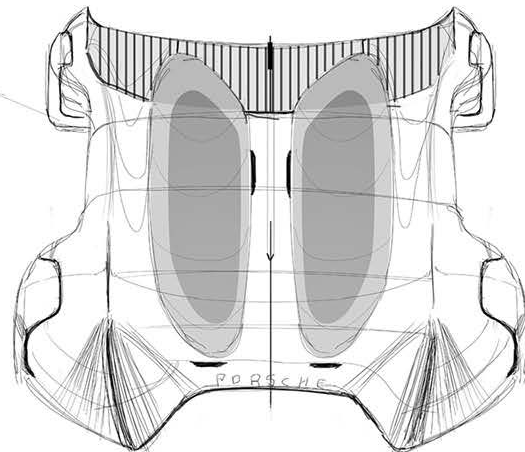

_ SPACE HIBERNATION

DURING YOUR JOURNEY, THIS VEHICLE WILL RE-ENERGIZE YOU WHILE YOU ARE AT YOUR DREAM.



STRUCTURE IDEATION 4
_ DEVELOPMENT

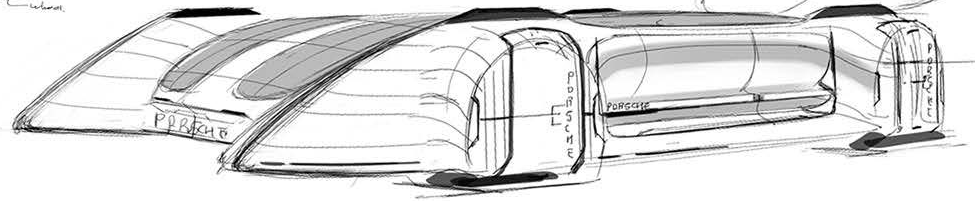
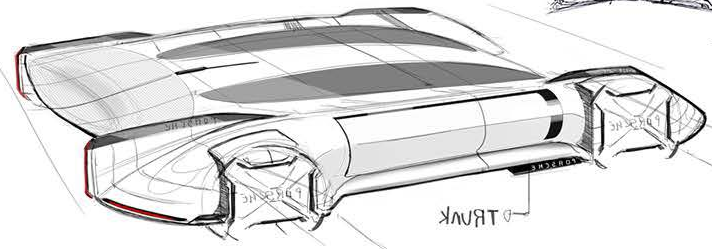
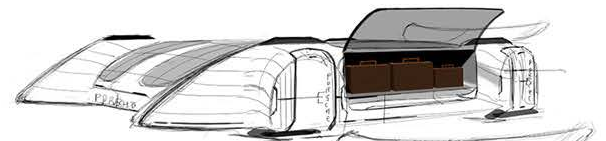
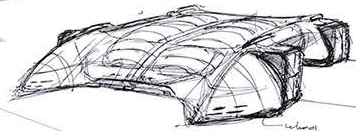
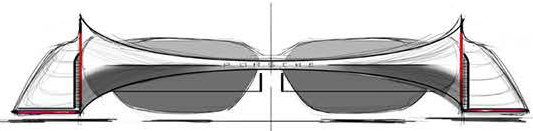
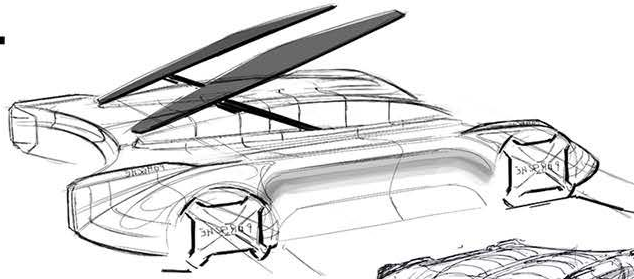

P O R S C H E
A M E R I C A

STRUCTURE IDEATION 4
_ DEVELOPMENT

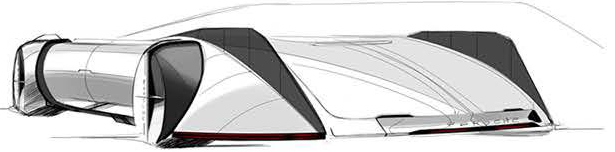
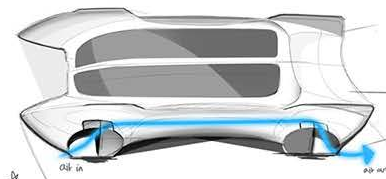
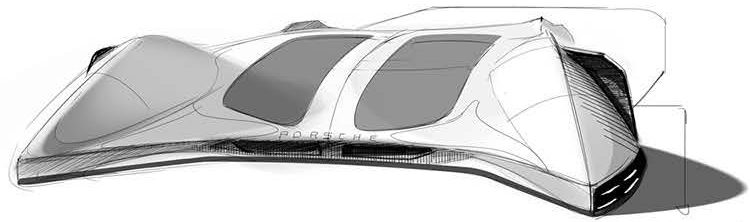

wheel exposed
+ air intake for windmill
generator

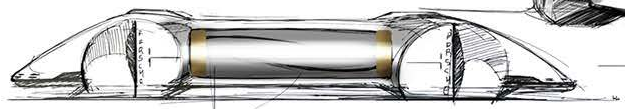
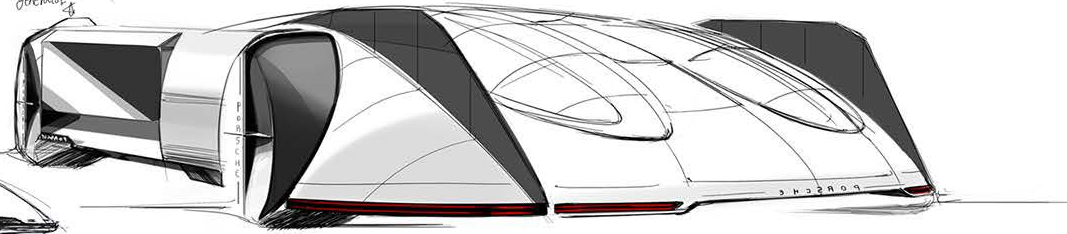

► ENERGY ROOM



CAPSULE CABIN

INSPIRED BY COSMETIC GOODS, ESPECIALLY IN TWO MATERIALS CONSIST OF TRANSPARENT/ TRANSLUCENT CABIN SPACE AND CABIN COVER TO PROTECT THE CABIN

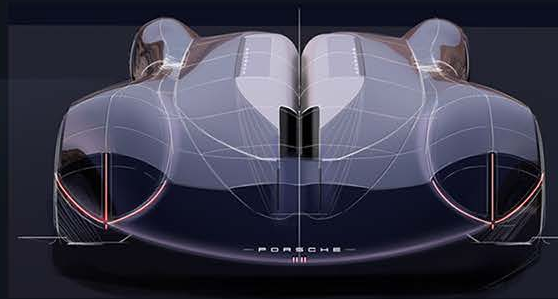
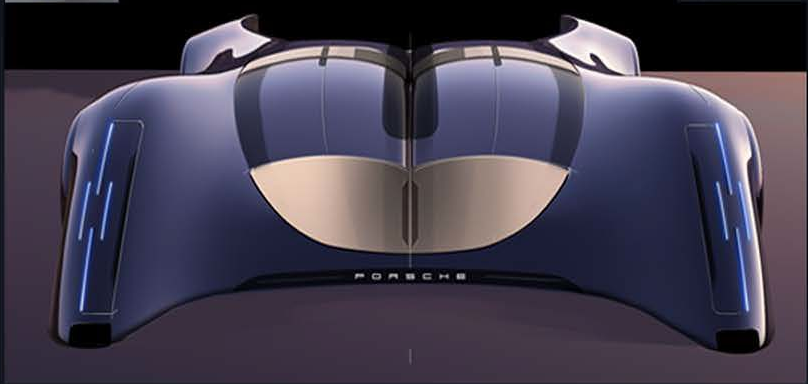
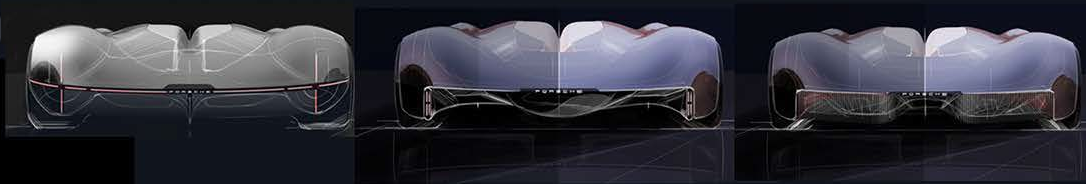

DEVELOPMENT

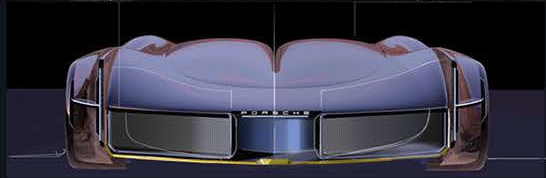

P O R S C H E
A V E N U E

TOP & SIDE EXPLORATION

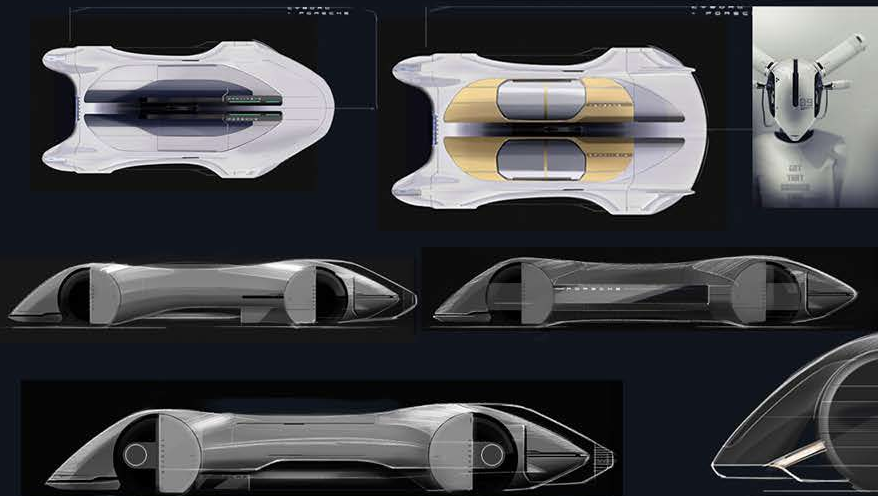

DEVELOPMENT

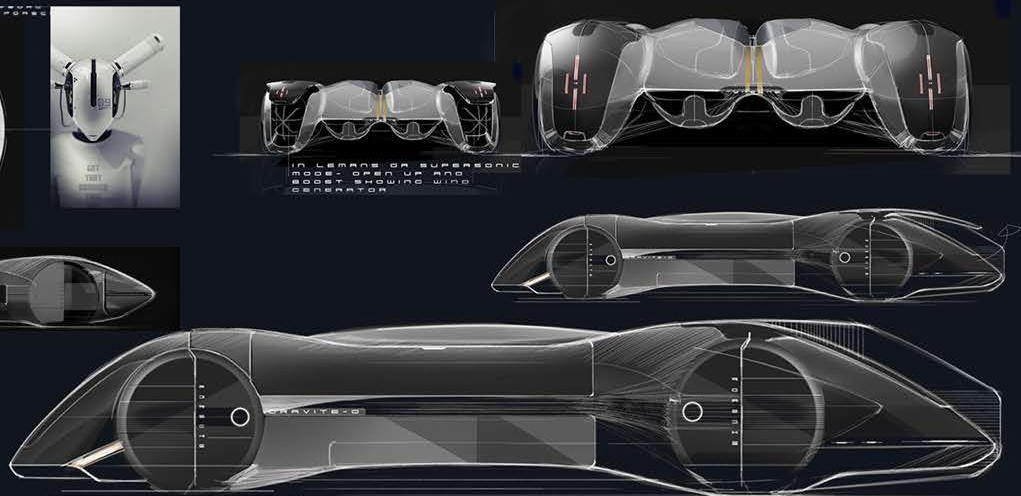

DEVELOPMENT

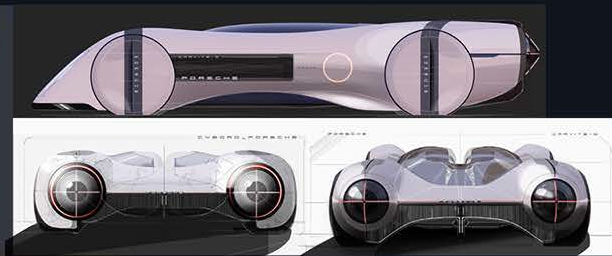
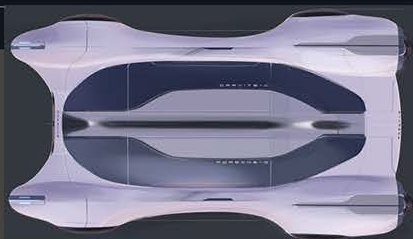
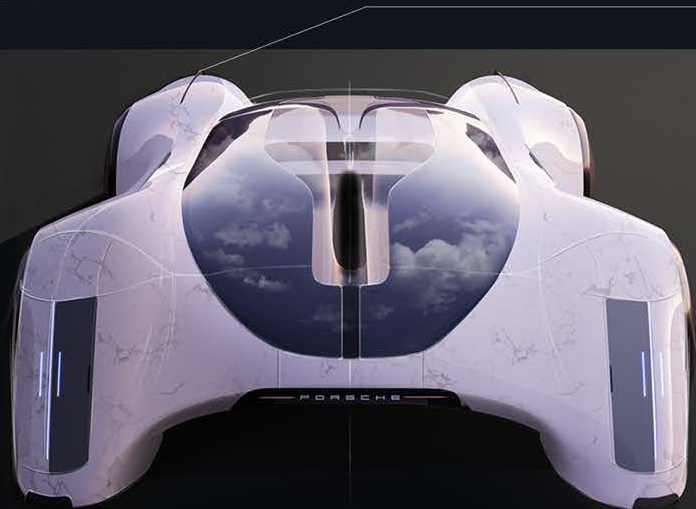

DESIGN SKETCH

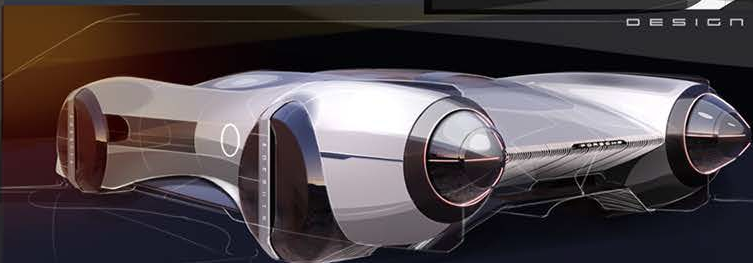

PULL OUT IN SUPER
OPTIC MODE



P O R S C H E
A U T O M O B I L E S



AIRCURTAIN / CHARGING LIGHT

THIS AIRCURTAIN STRUCTURE HELPS AIR FLOW MORE EFFICIENTLY. EVERY LIGHT SENSOR ON THE CURTAIN PORTRAYS WATERFALL IN CHARGING MODE TO MAKE THIS VEHICLE LOOK MORE ALIVE.



ENERGY FLOWS INTO THE REACTOR

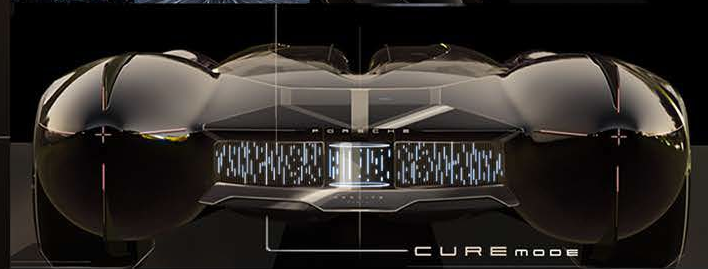

CURE mode

MARBLE SCULPTURE

LUXURIUS AND EXPENSIVE VEHICLE'S OWNER DESERVES LUXURIUS AND EXPENSIVE WELCOME AND PLEASURE THROUGH MATERIAL AND RED CARPET GRAPHIC.

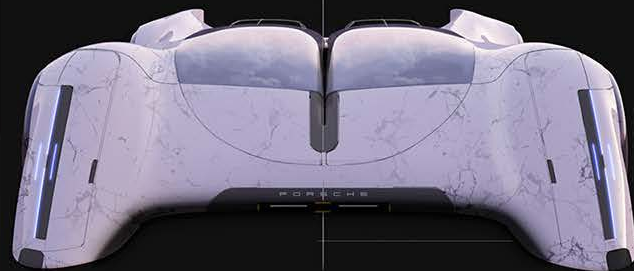

MAIN ENTRANCE AT THE FRONT + EXPENSIVE
VEHICLE = WELCOME CEREMONY WITH RED
CARPET



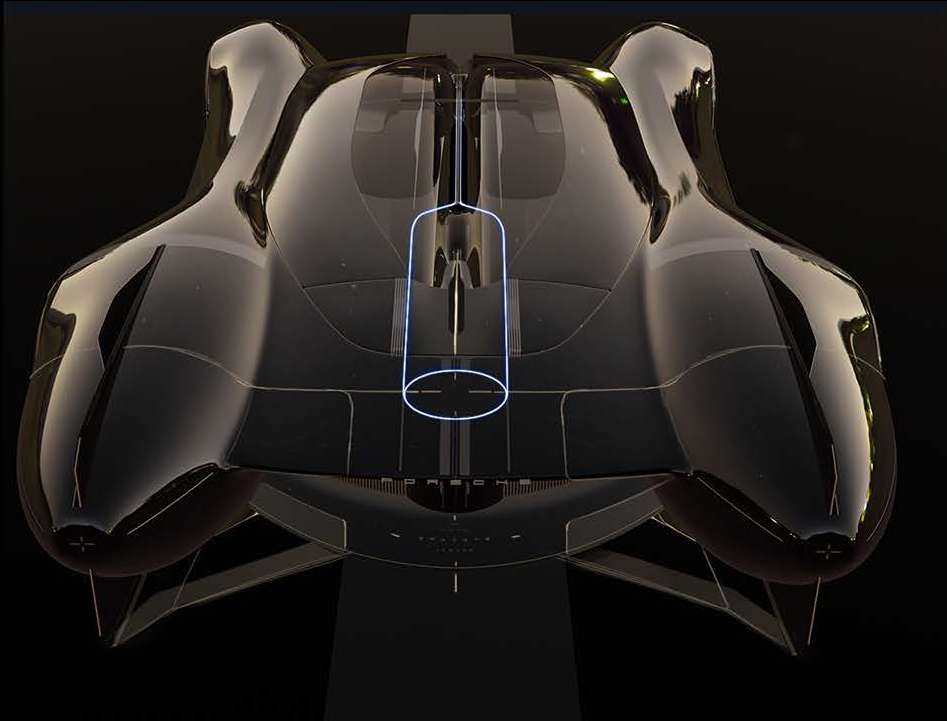

AIRCRAFT DIFFUSER

THIS VEHICLE WILL BE ON THE SKY-HYPER ROAD WITH MORE THAN 1000 HP. BECAUSE OF THIS, THIS MACHINE NEEDS MORE THAN JUST A AUTOMOTIVE DIFFUSER

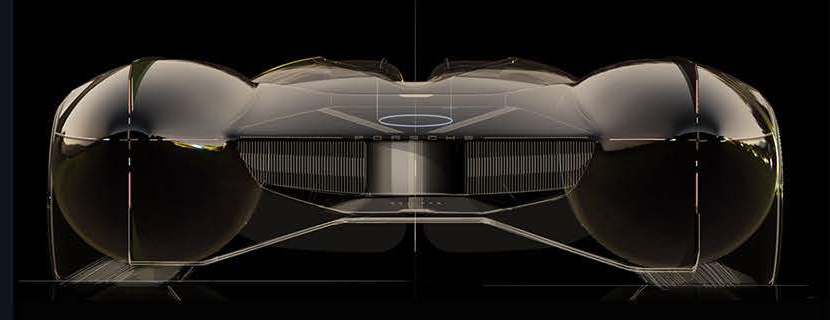
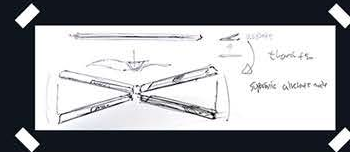

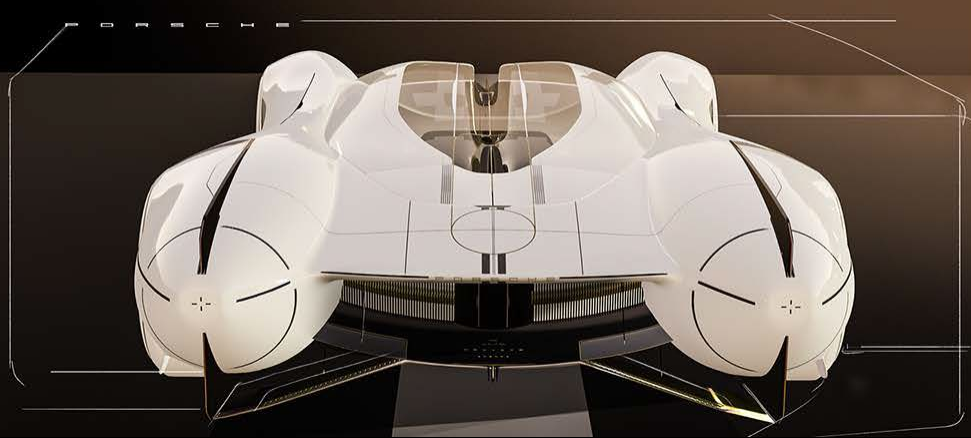
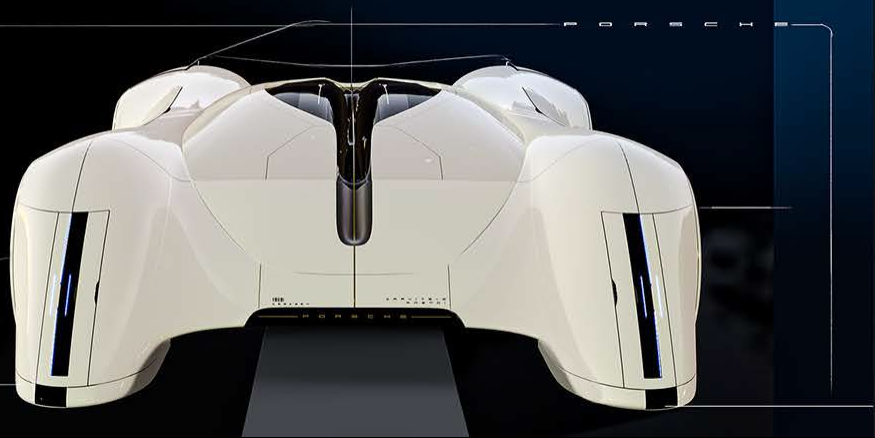

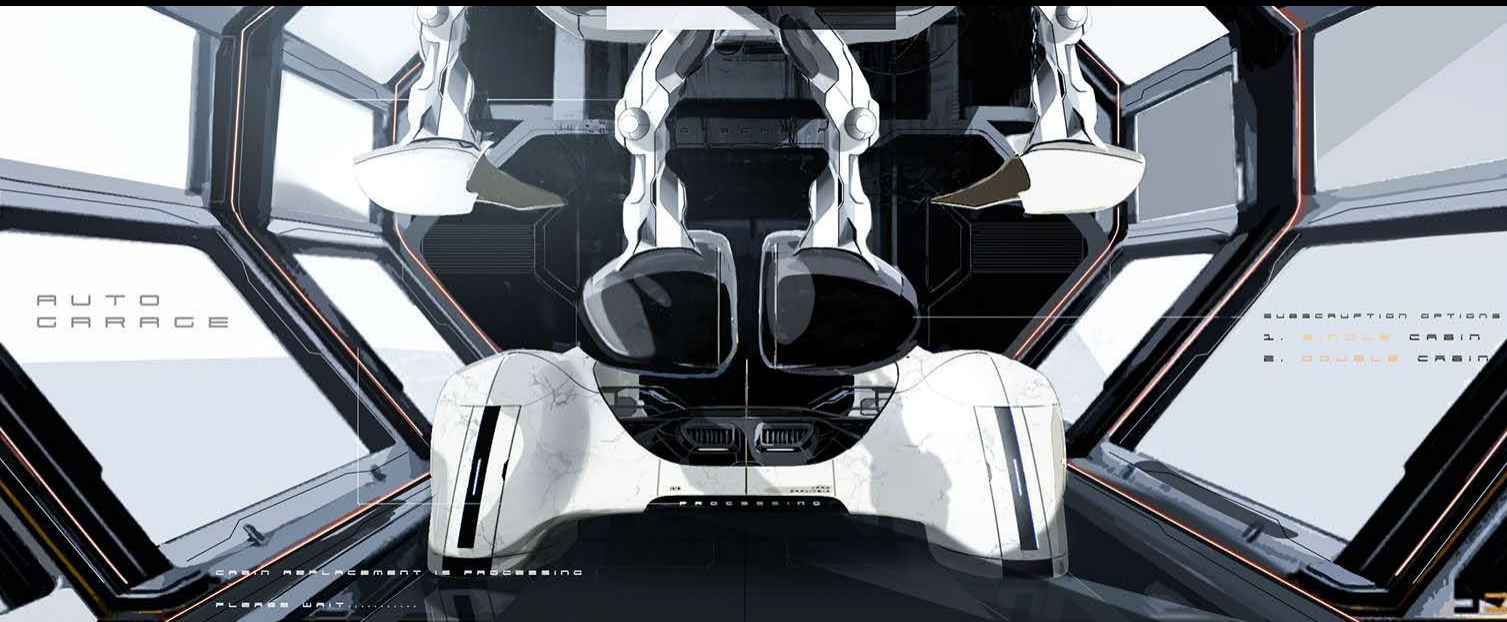

AUTO
GARAGE

SUBSCRIPTION OPTIONS
1. SINGLE CABIN
2. DOUBLE CABIN

CABIN REPLACEMENT IS PROCESSING
PLEASE WAIT.....

A. SINGLE CABIN
-LEMAN EDITION



B. DOUBLE CABIN
-CURB EDITION



P O R S C H E

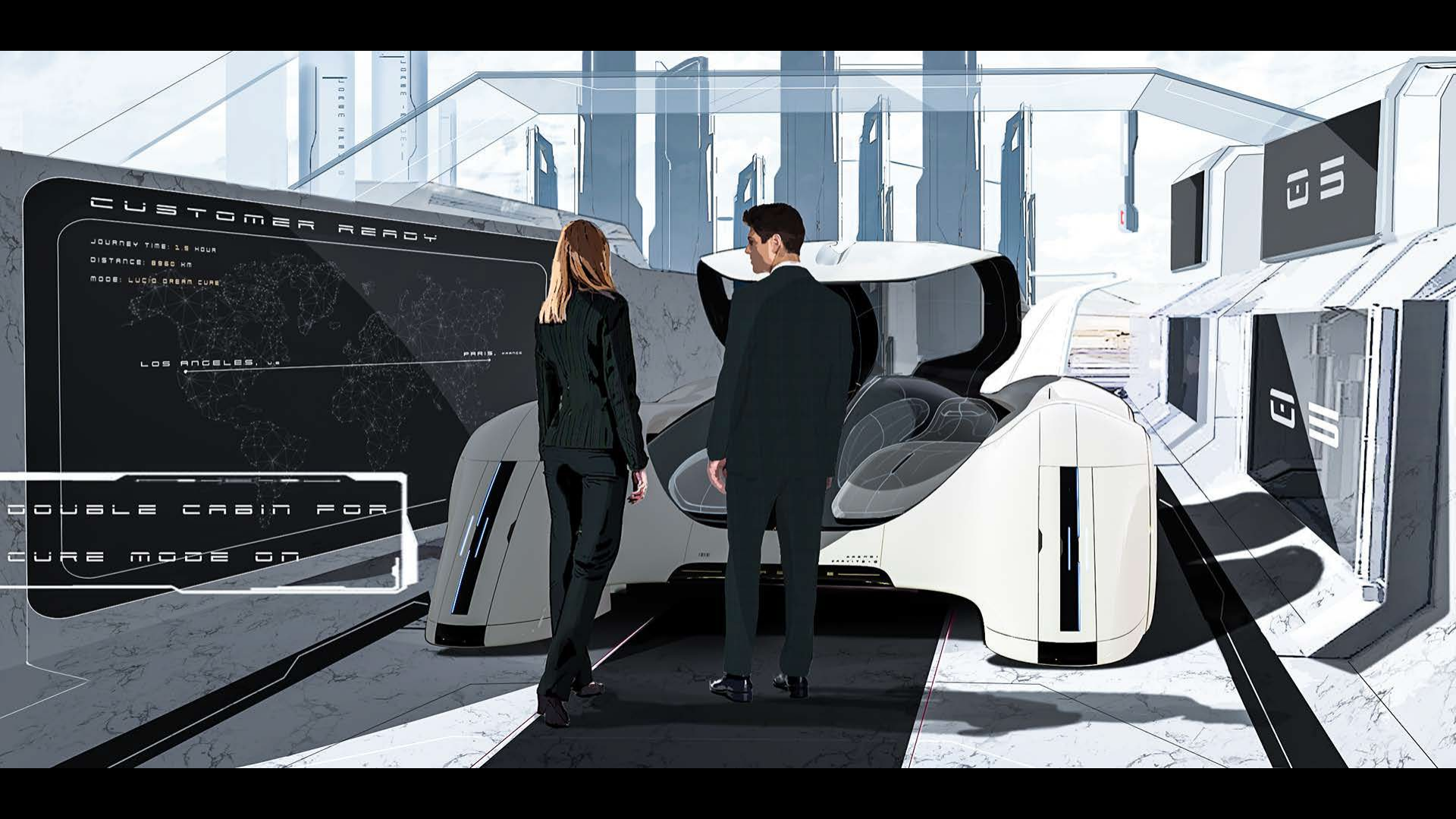

CUSTOMER READY

JOURNEY TIME: 1.5 HOUR
DISTANCE: 8880 KM
MODE: LUCID DREAM CURE

LOS ANGELES, CA PARIS, FRANCE

DOUBLE CABIN FOR
CURE MODE ON

A.C 200 PORSCHE SKY HYPERWAY

:::WORLD IS INTERCONNECTED WITH
SKY HYPERWAY AROUND THIS TIME

SPEED LIMIT 1200 KM/H

LA TO SEOUL

1 MILE LEFT

INTERCONTINENTAL
HYPERWAY - 1



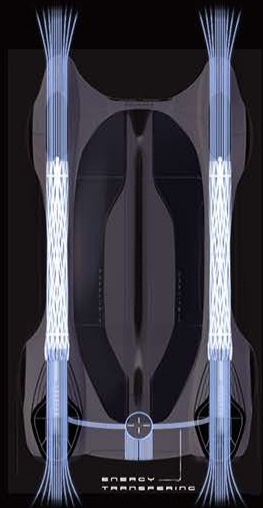

WIND BOOSTER SYSTEM

AS YOU CAN SEE UP THERE, THIS VEHICLE USE WIND POWER BOTH TO GENERATE ENERGY AND BOOST BY SUCKING UP THE AIR FROM FRONT VENT AND LET IT FLOW THROUGH VIA REAR VENTS.

LOS ANGELES
U.S.A

FINAL DESIGN

P O R S C H E
A E R O I

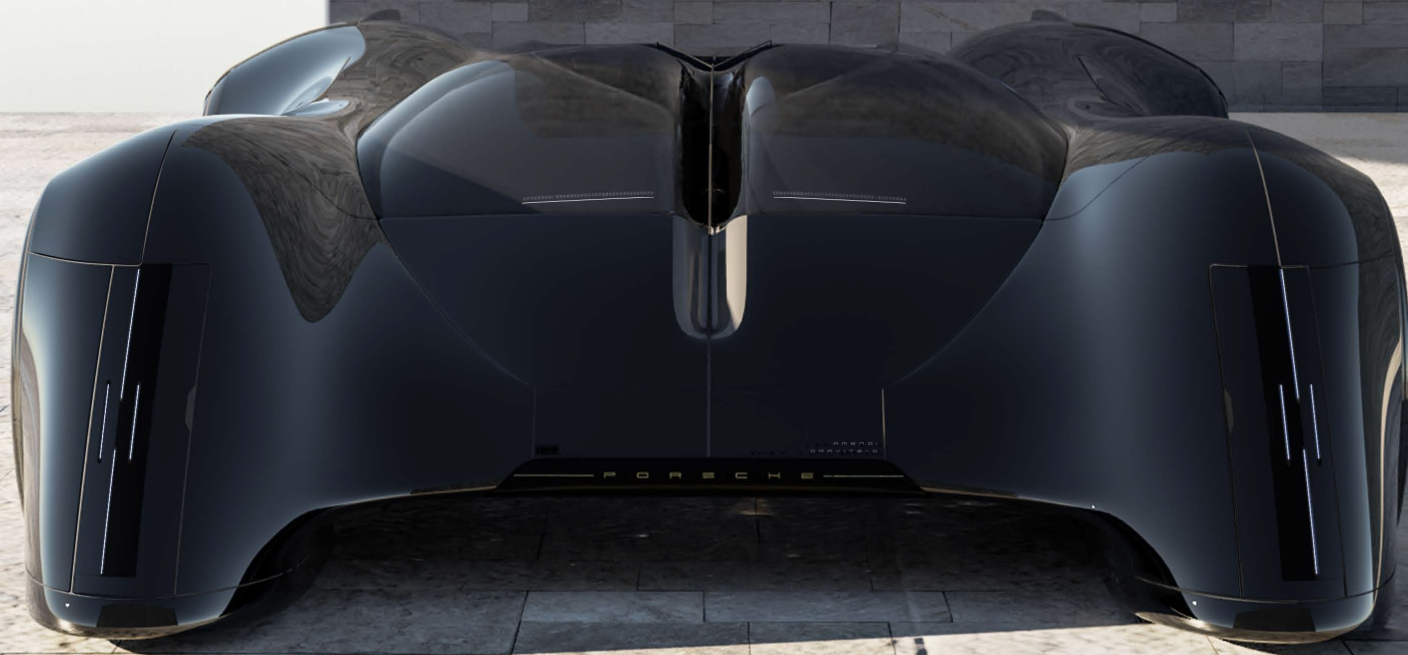

U L T I M A T E F U T U R E E N E R G Y

P O R S C H E
A B E N D U N G

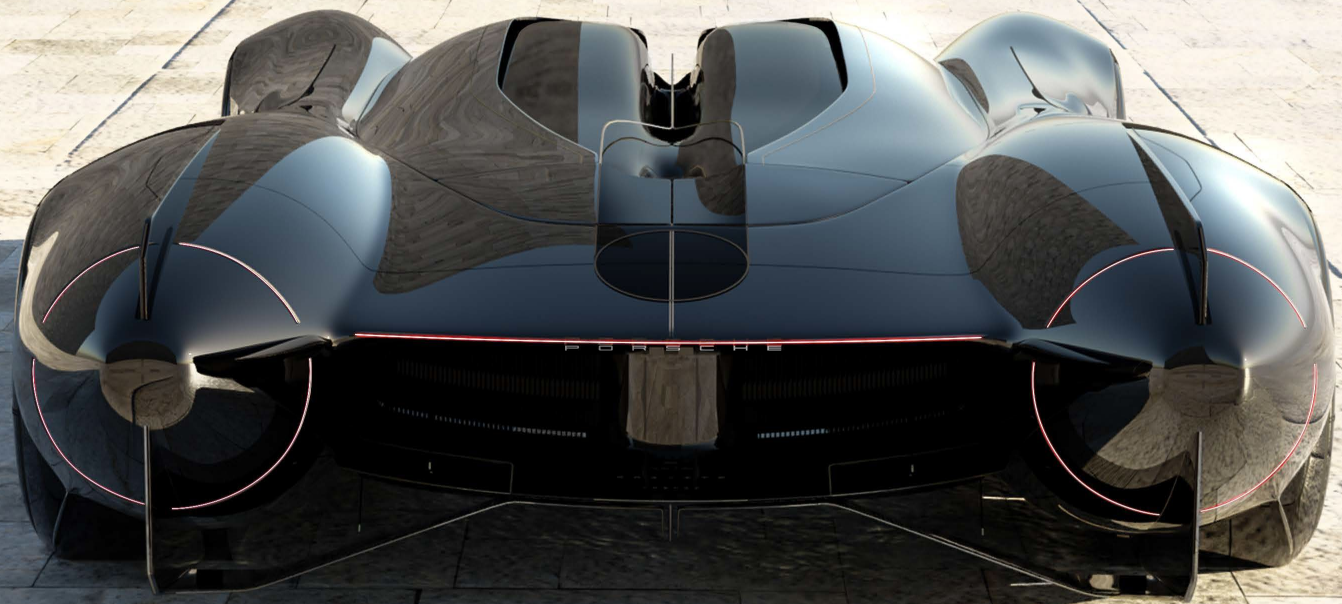

U L T I M A T E F U T U R E E N E R G Y

P O R S C H E
A M E N O I



U L T I M A T E F U T U R E E N E R G Y

P O R S C H E
A E R O I

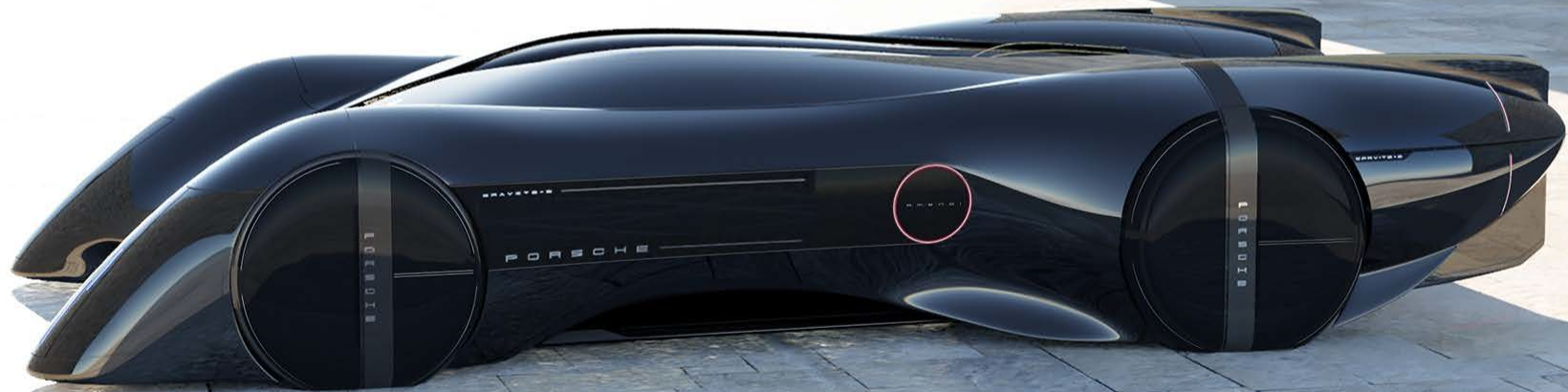

C U T T E R A T E P U C T U R E M E M B E R S

P O R S C H E
F E R R A R I



ULTIMATE FUTURE ENERGY

P O R S C H E
A M E N O I
U L T I M A T E F U T U R E E N E R G Y







P O R S C H E
U L T I M A T E F U T U R E B O D Y

P O R S C H E
A E L O I
ULTIMATE FUTURE ENERGY



P O R S C H E
A B E N D O I
ULTIMATE FUTURE ENERGY

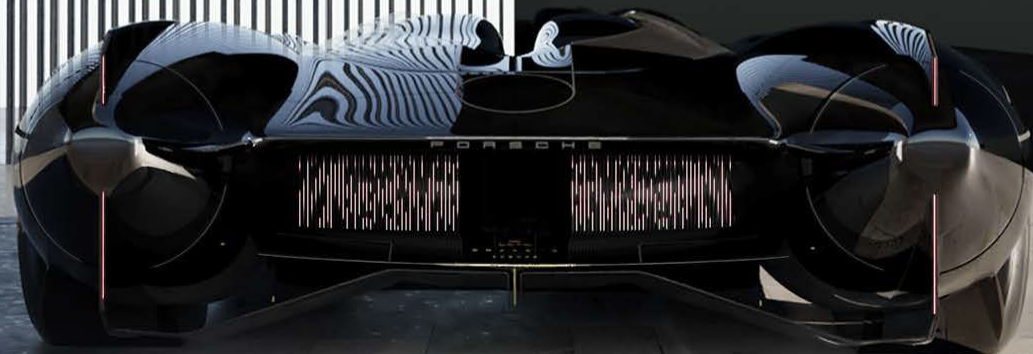

I N T E R I O R D E S I G N



IMMERSE YOURSELF TO THE VERY DEEP INSIDE AND **REST.**

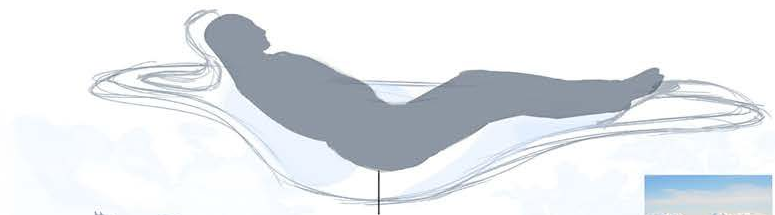

THIS LIQUID SEAT/BED NATURALLY FLOW ALONG WITH
CUSTOMER'S BODY LINE

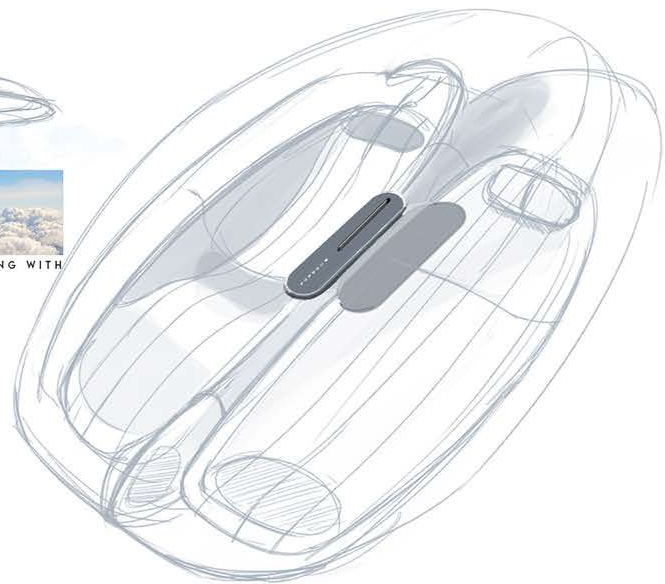
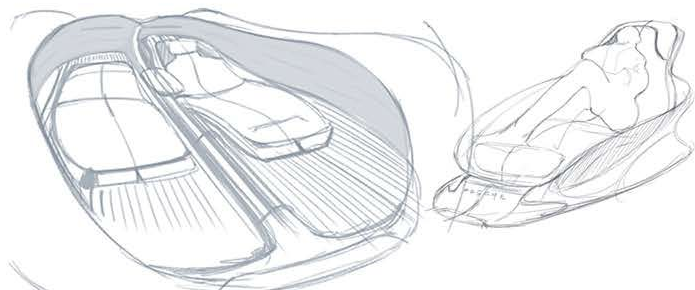

THEME SKETCH

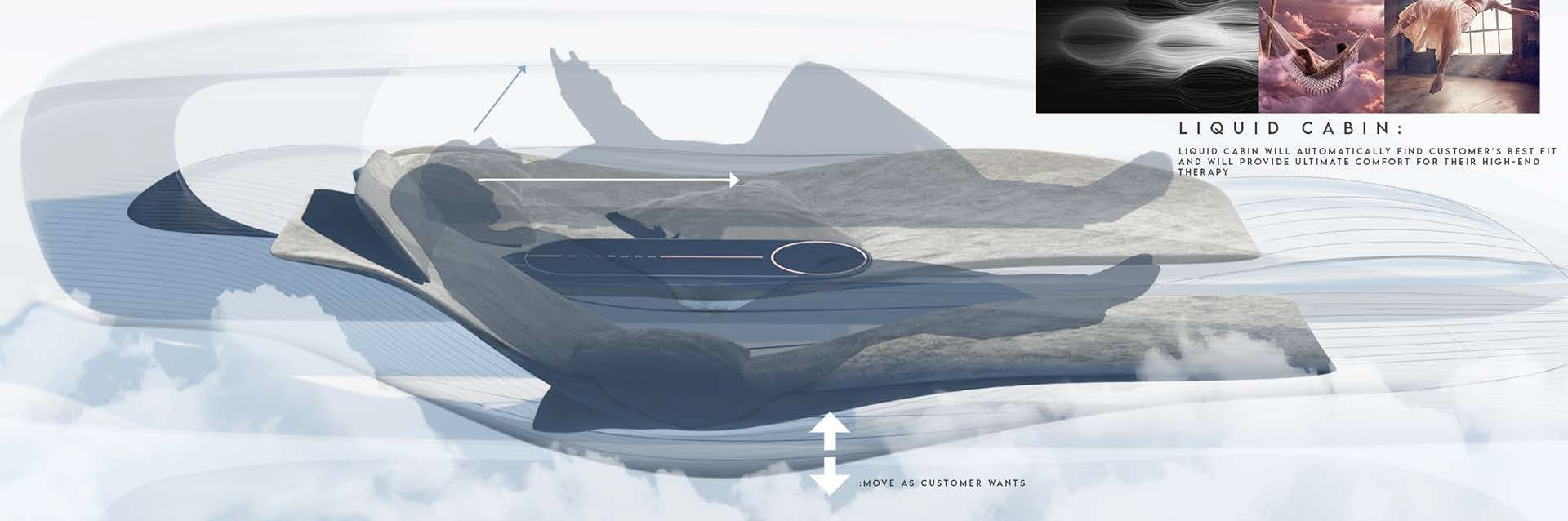

:MOVE AS CUSTOMER WANTS



LIQUID CABIN:

LIQUID CABIN WILL AUTOMATICALLY FIND CUSTOMER'S BEST FIT AND WILL PROVIDE ULTIMATE COMFORT FOR THEIR HIGH-END THERAPY

L I Q U I D C A B I N
U L T I M A T E P E R F O R M A N C E P O S T U R E



L I Q U I D C A B I N :

L I Q U I D C A B I N W I L L A U T O M A T I C A L L Y F I N D S C U S T O M E R ' S B E S T F I T , A N D W I L L P R O V I D E U L T I M A T E C O M F O R T F O R T H E I R H I G H - E N D T H E R A P Y





WIND TEXTURE:

EACH INFRARED LIGHT ON THE WALL NOT ONLY PROVIDE WARM AND REFRESH THERAPY BUT ALSO REPRESENTS WIND SHAPE

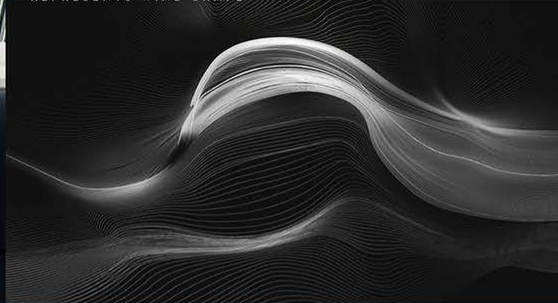

INFRARED THERAPY:

WHILE ON YOUR JOURNEY, THIS INFRARED LIGHTS WILL PERFORM TO PROVIDE PROPER THERAPY



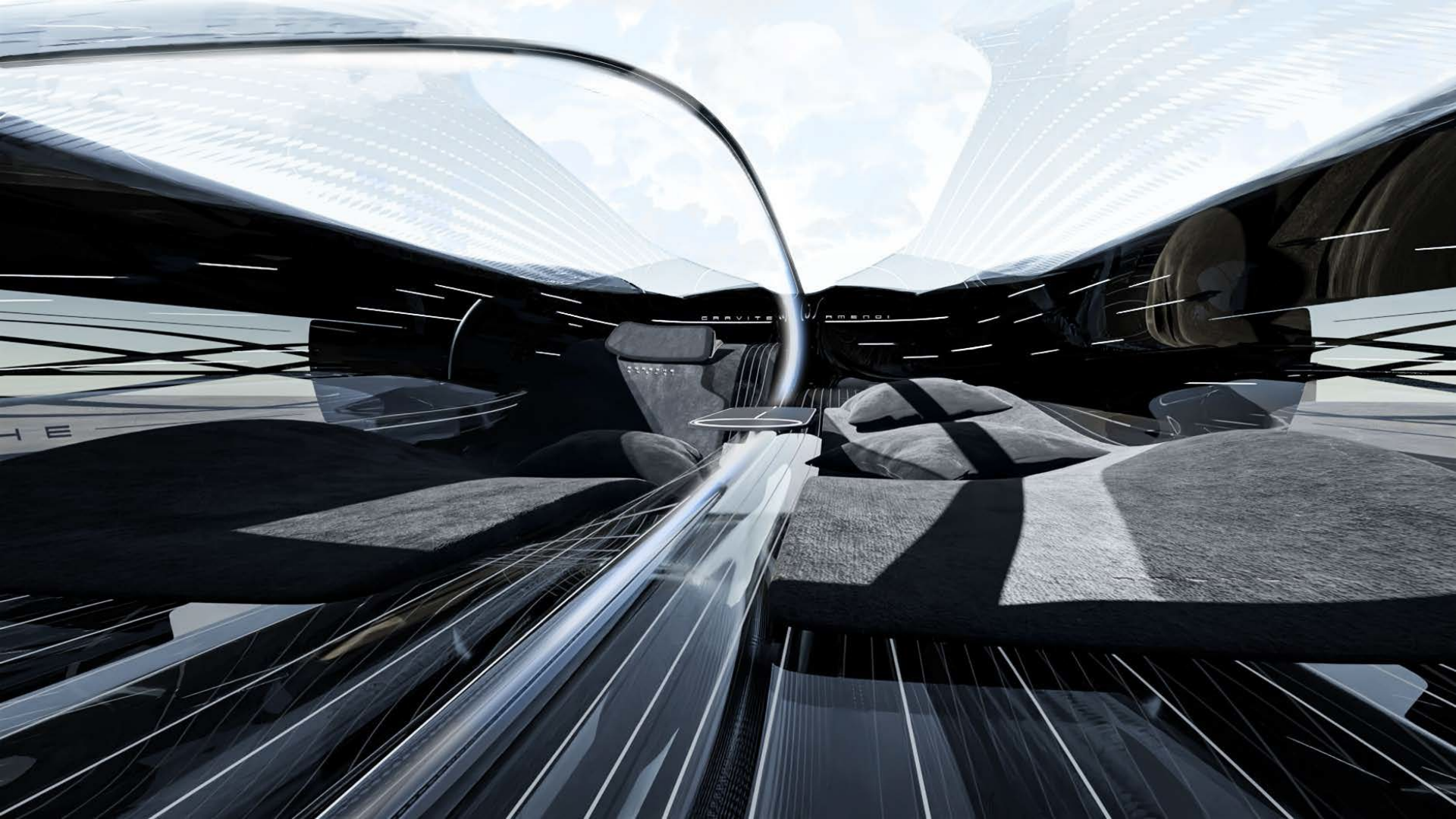

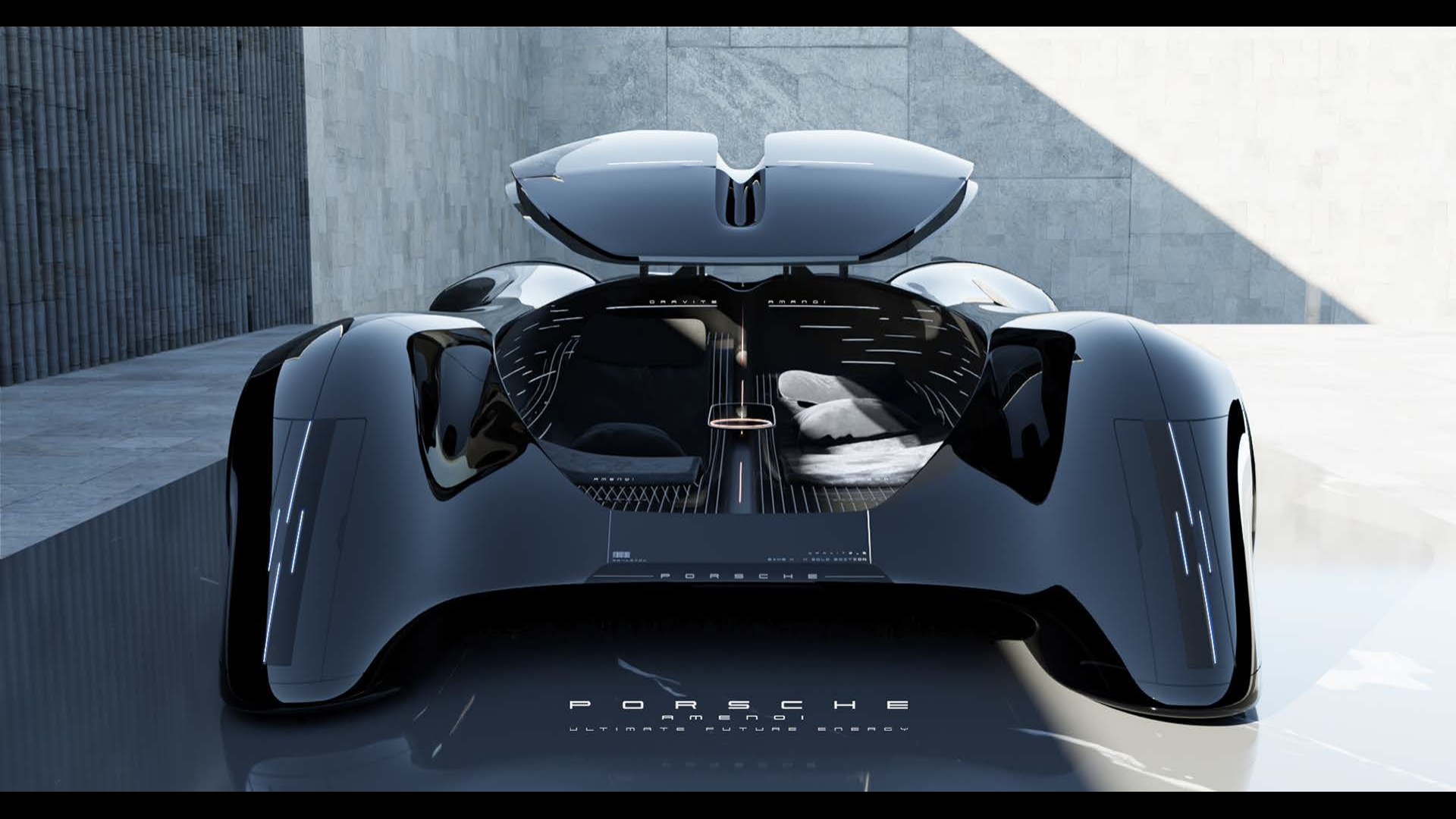

GRAVITY

ABRARDI

ABRARDI

ABRARDI

ABRARDI

PORSCHE

PORSCHE
ULTIMATE FUTURE ENERGY

LE MANS EDITION
S I N G L E C A B I N

P O R S C H E
A 3 E N O I
E D I T I O N L E A D S





P O R S C H E
R E M O L D I
E D I T I O N L E M A N S

P O R S C H E
R A M E N D O I
E D I T I O N L E M A N S





P O R S U C H E
E D I T I O N I E S T A N S
E D I T I O N I E S T A N S

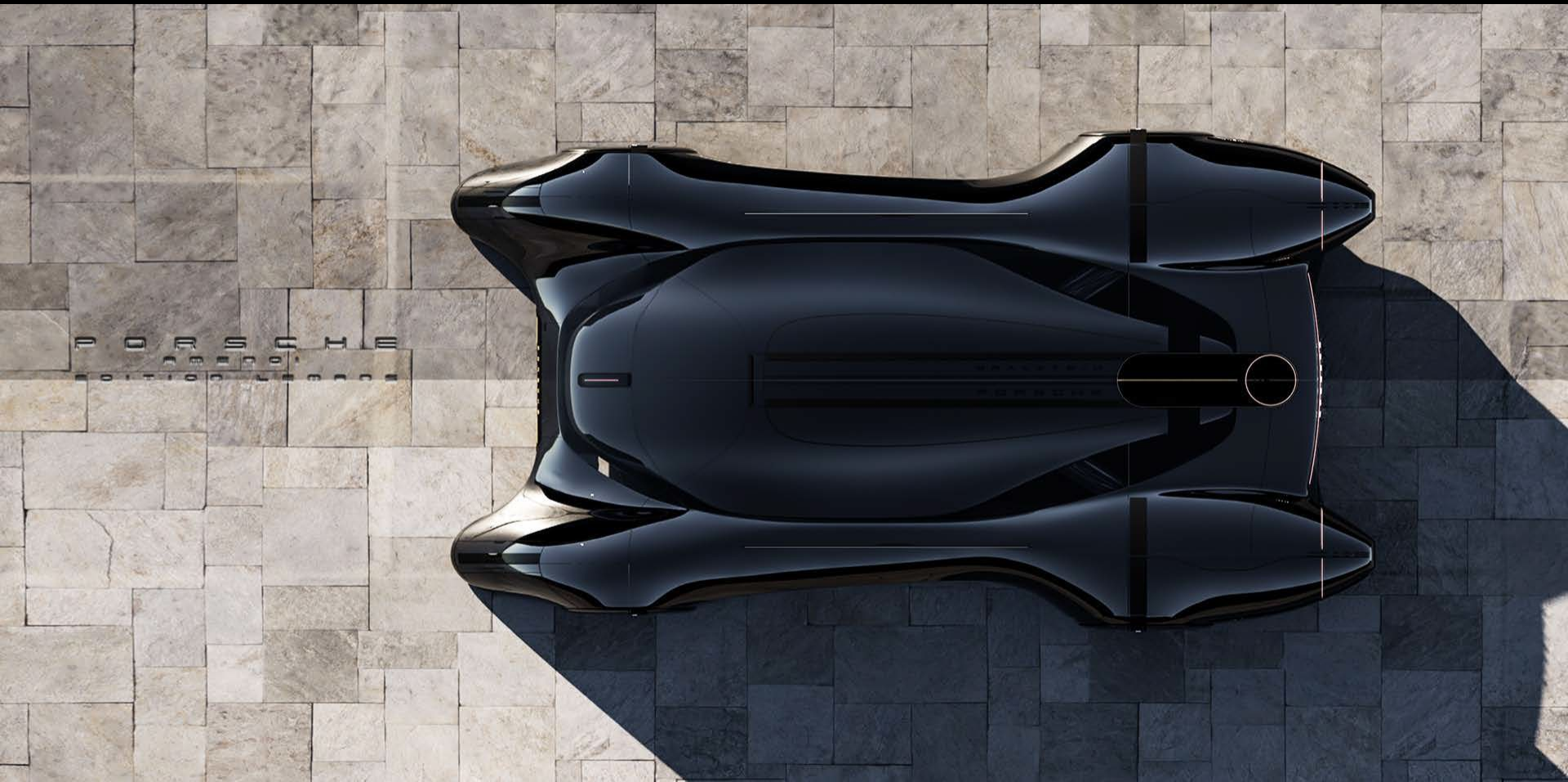



1ST STAGE SKY HYPER WING

0 - 150KM/H

PORSCHE AMENOI

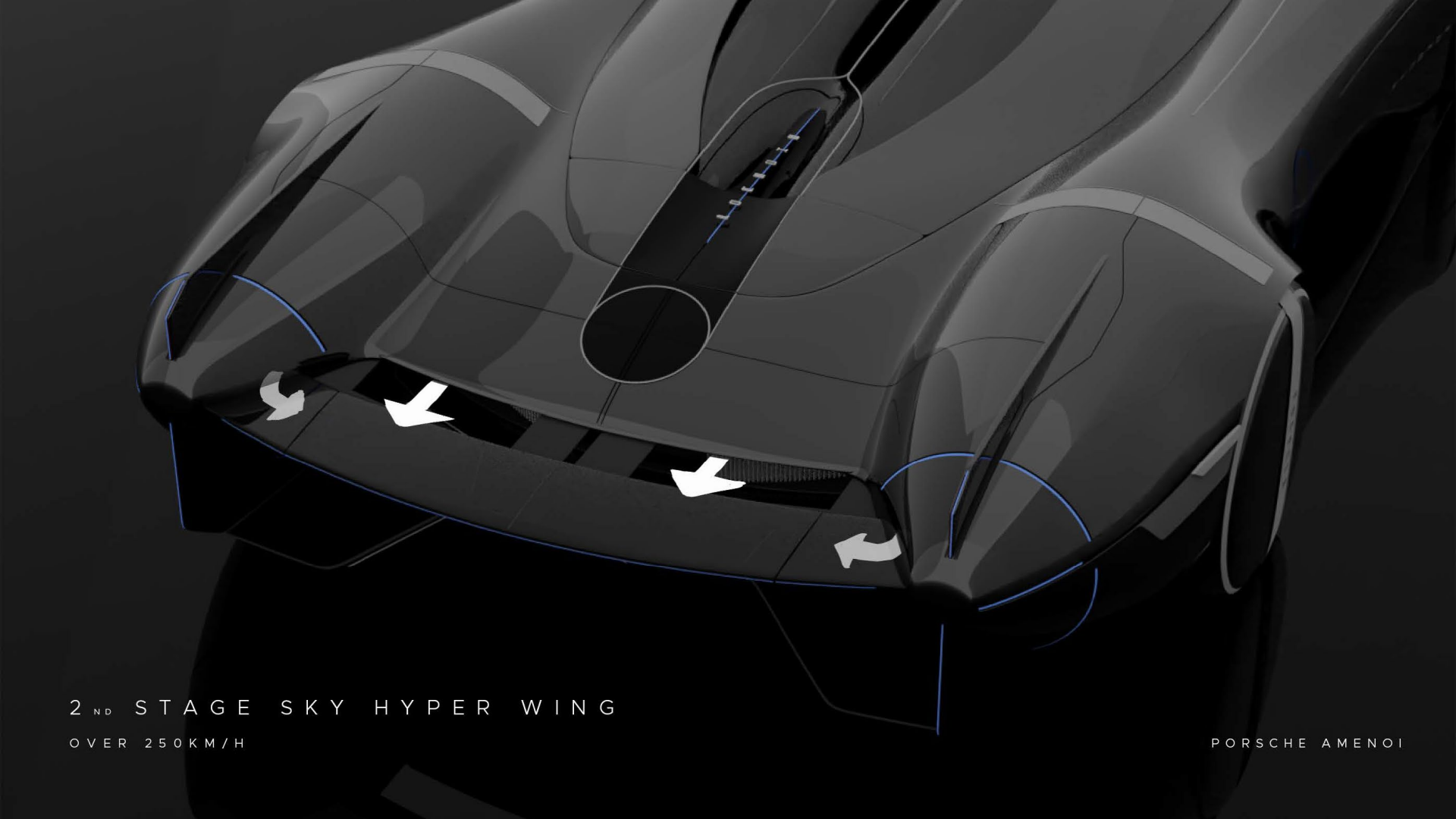

2ND STAGE SKY HYPER WING

OVER 250KM/H

PORSCHE AMENOI



3RD STAGE SKY HYPER WING

OVER 350KM/H

PORSCHE AMENC

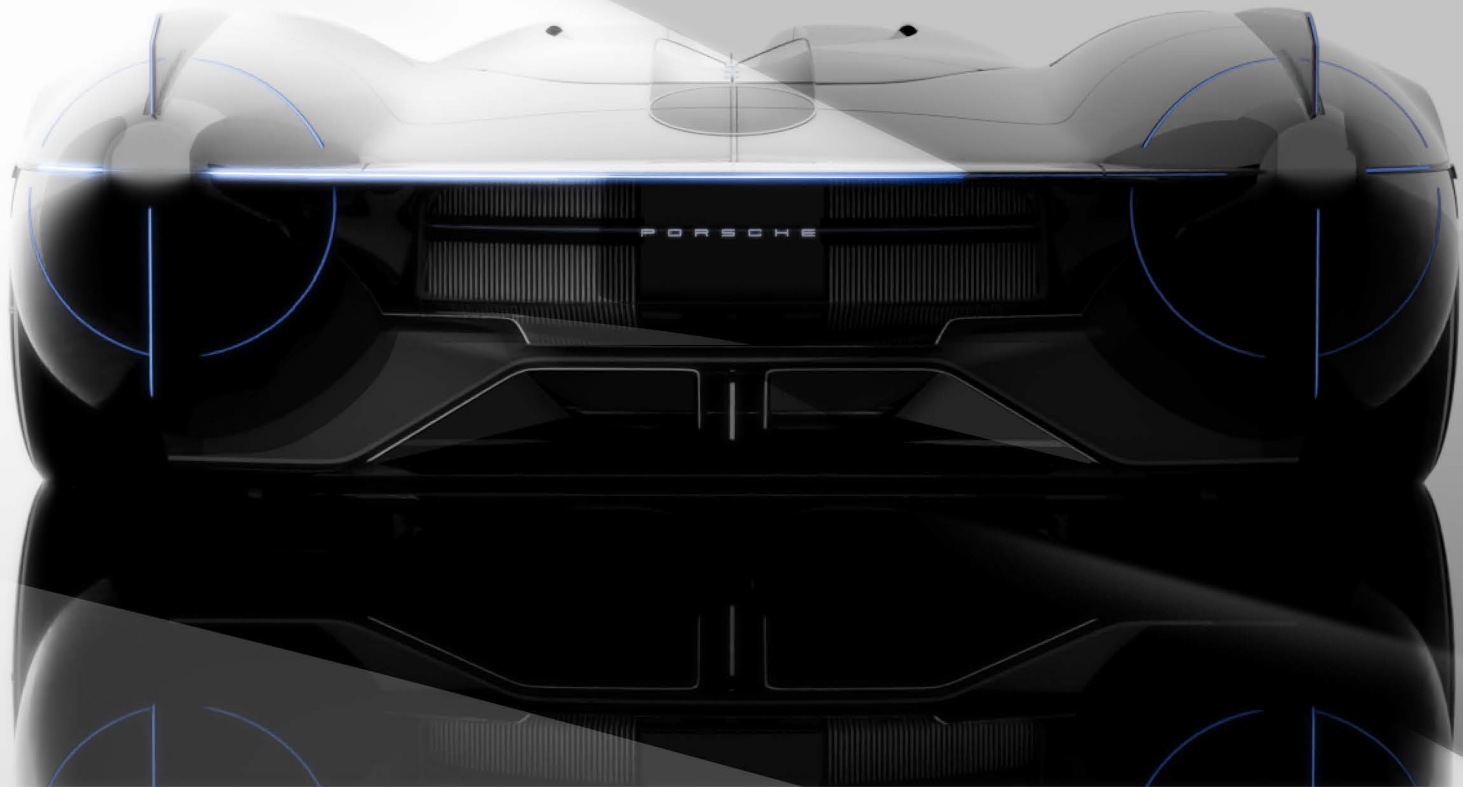

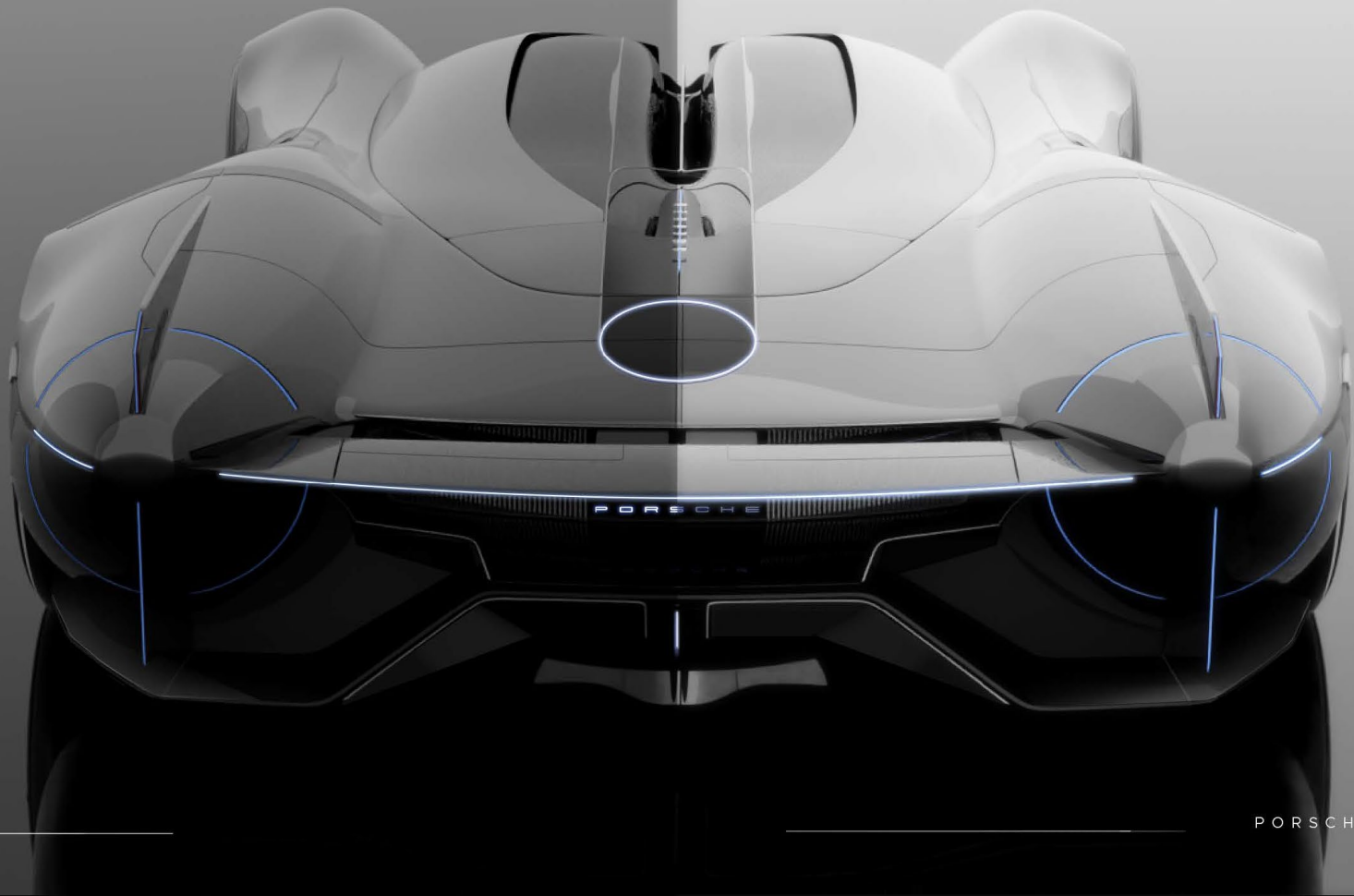

PORSCHE

PORSCHE AMENOI

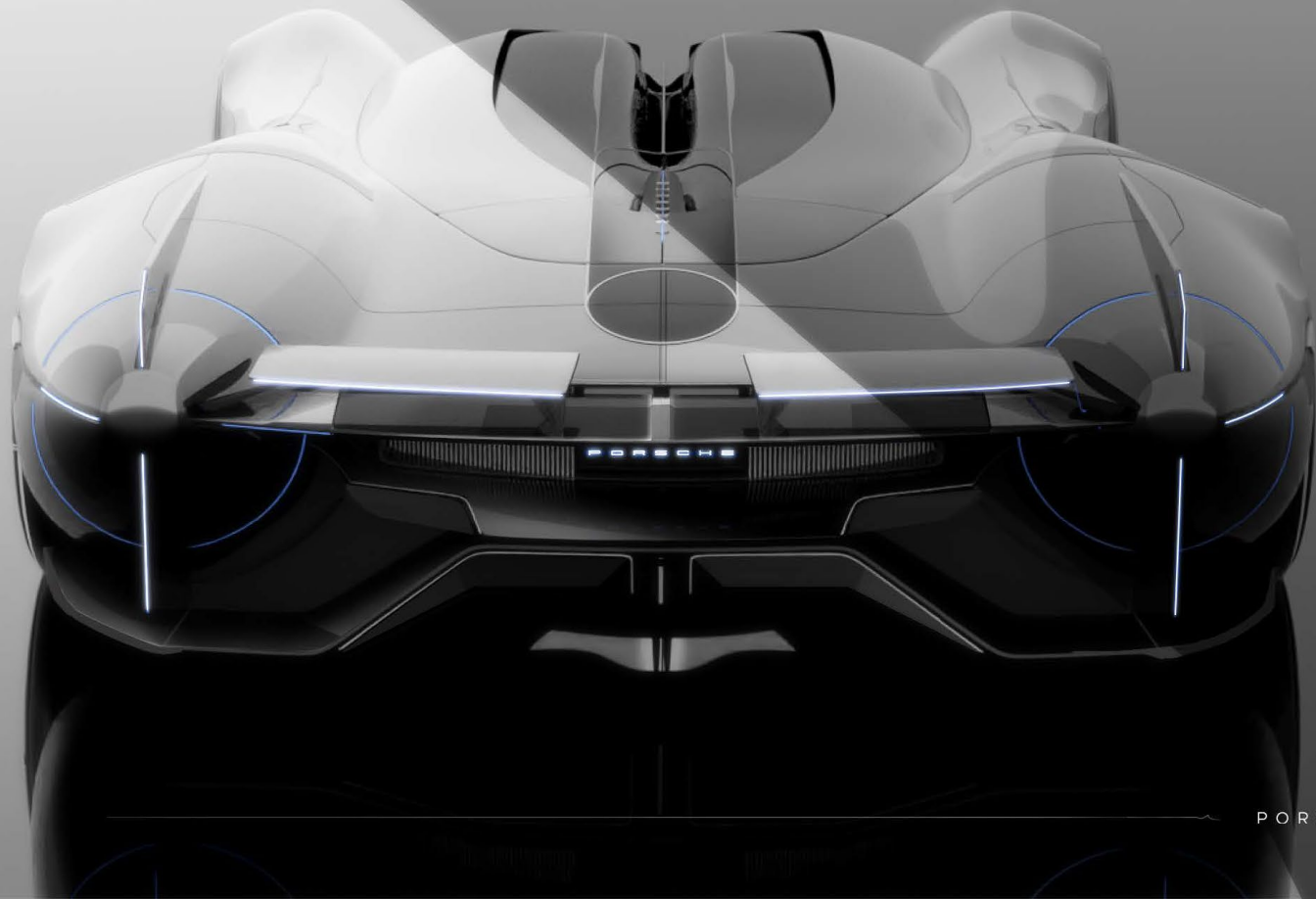

PORSCHE AMENOI

AMENDO
MIOBROJ





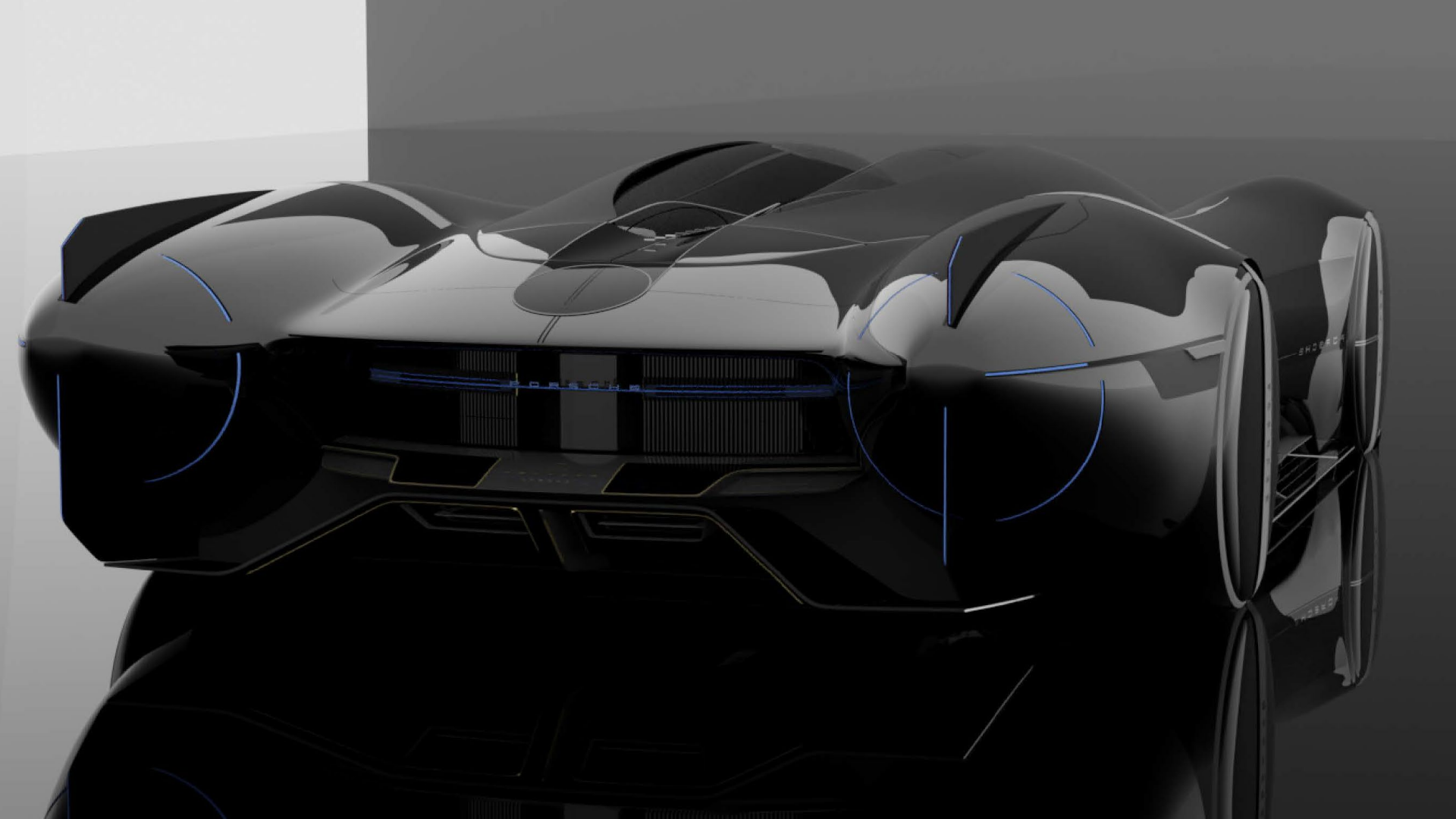

HALIOI

 Team Halioi Fall 2021

Meet the Team



Jenner Poulsen

Industrial Design

Team Leader
and Clay Sculptor



Dong Joo (DJ) Kim

Industrial Design

Exterior Designer



David Y. Kim

Industrial Design

Interior Designer



Jiaxin Xie

Web New Media

UI/UX Designer



Chieh Hsin (Asin) Cheng

Interior Architecture
and Design

Exterior and Interior
Architecture Designer

Concept Statement

RE-IMAGINED LUXURY IN A RE-IMAGINED WORLD

Manifesto:

Setting the standard for the unknown future. Halioi is doing exactly that.

Adapting to the new world in the most sustainable and seamless way possible.



80% OF THE WORLD HAS SUBMERGED INTO THE OCEAN

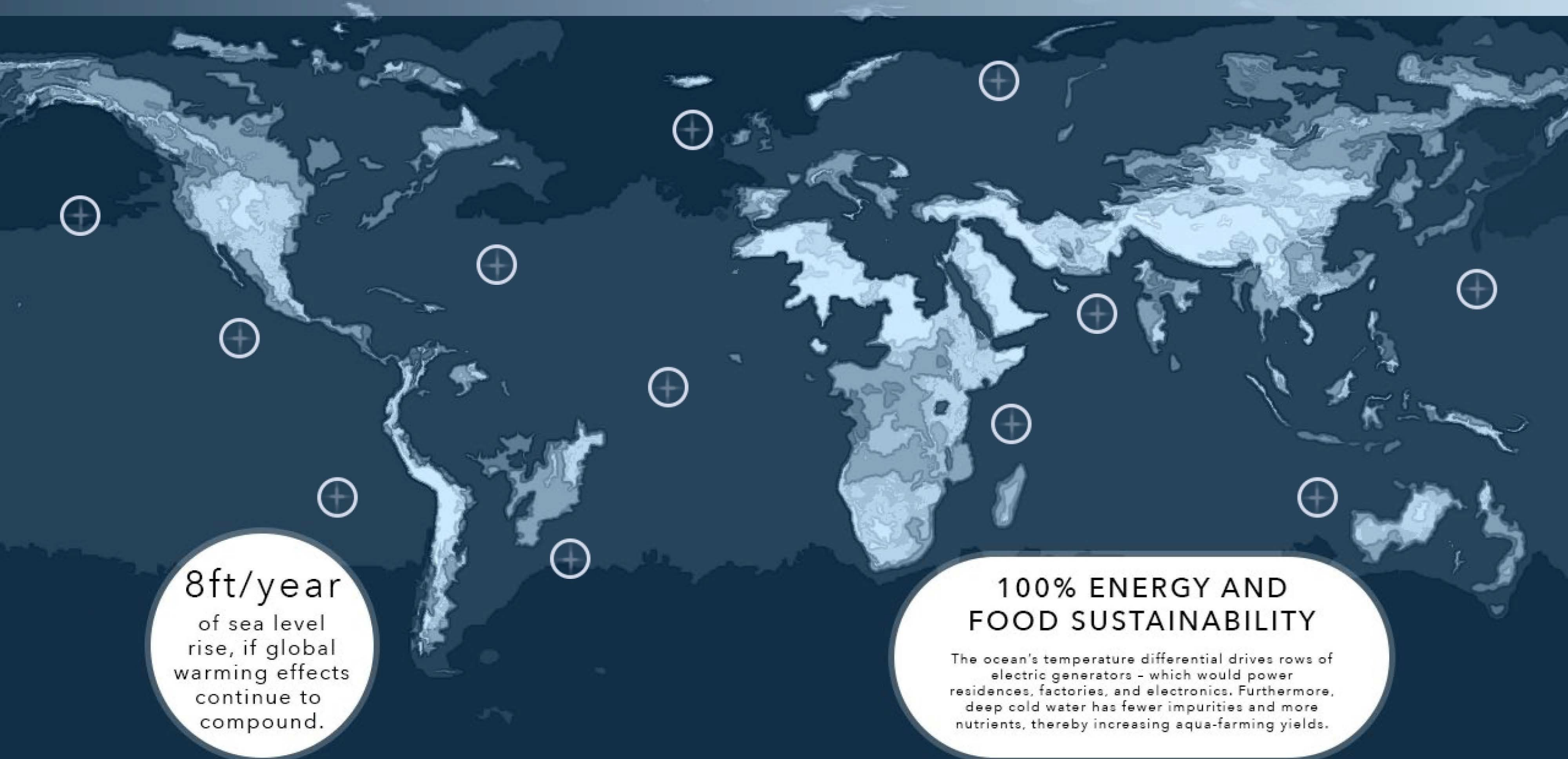

8ft/year
of sea level
rise, if global
warming effects
continue to
compound.

**100% ENERGY AND
FOOD SUSTAINABILITY**

The ocean's temperature differential drives rows of electric generators - which would power residences, factories, and electronics. Furthermore, deep cold water has fewer impurities and more nutrients, thereby increasing aqua-farming yields.

EXPERIENCE

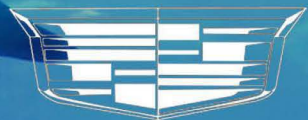

Cadillac

C O M M U N I C A T I O N

REIMAGINED UI/UX BETWEEN HUMANITY & OCEAN
LISTEN TO THEIR LIFE STORY

AUDITORY EXPERIENCE
RE:IMAGINED LUXURY PART I

TALK TO THEM

CONTRIBUTION



P U R I F I C A T I O N

REIMAGINED CORELATIONSHIP BETWEEN HUMANITY & OCEAN

PAY BACK TO THE OCEAN

GLANCE AT THE LIFESTYLE IN 2039

A DAY OF WORK AND RELAXATION WITH
JORDON AND DEJA

BEGIN



_STORY BOARD

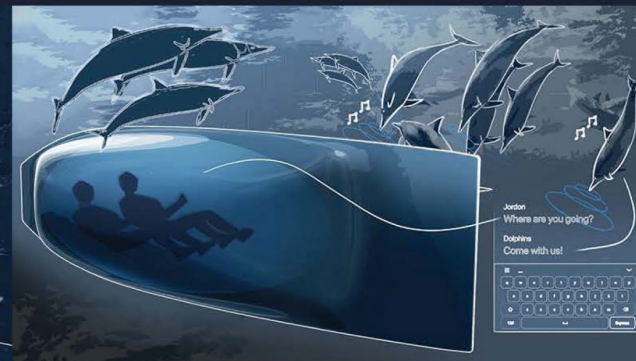
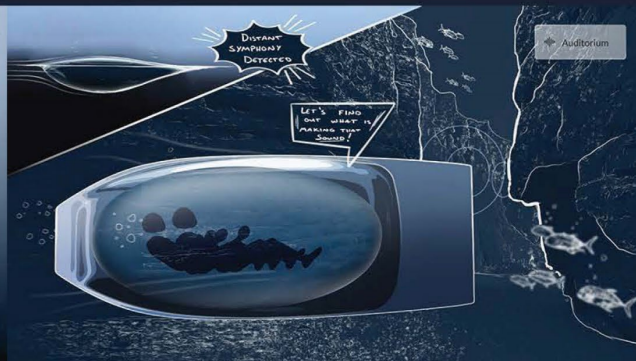
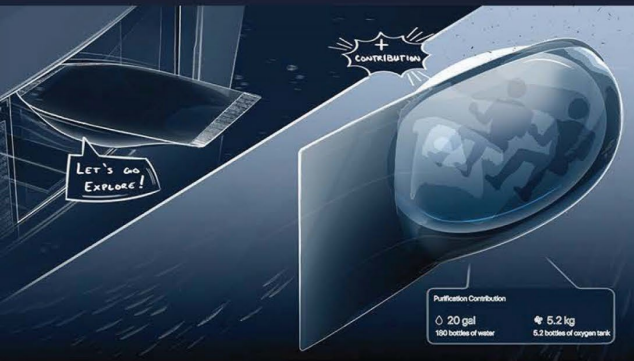
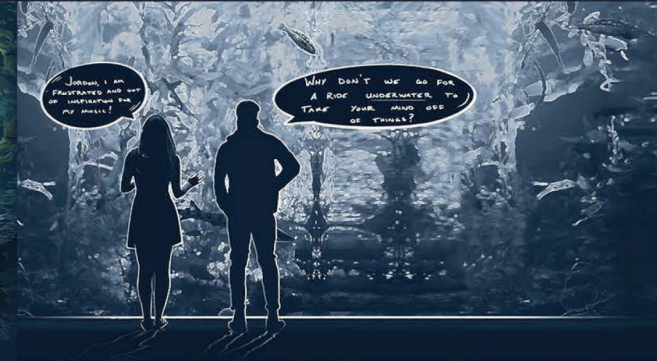
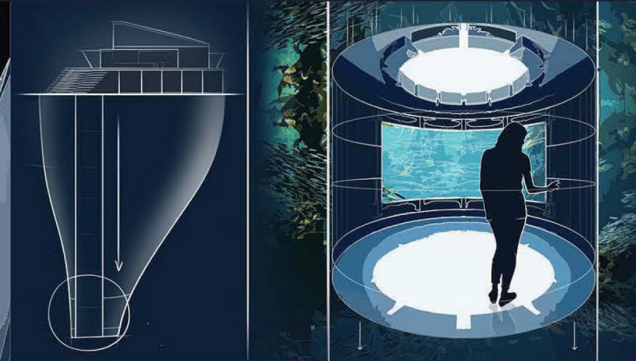
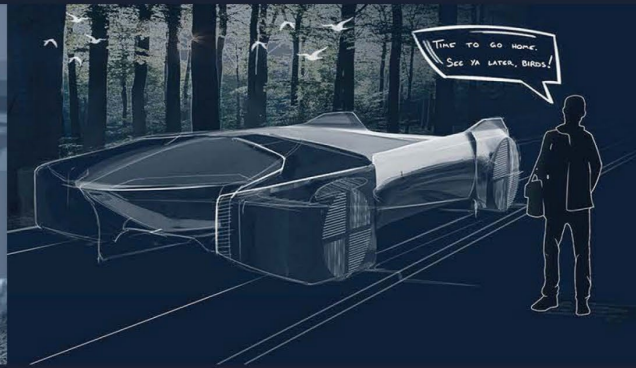



WOAH!! WHAT IS THIS PLACE? THERE IS A SYMPHONY DOWN THERE!

RE-IMAGINED SUSTAINABILITY

CADILLAC

H A L L O I



VISUAL FANTASY LUXURY VISUAL EXPERIENCE IN YOUR HOTEL ROOM.

OUR ARCHITECTURE'S BIOLUMINESCENCE SUSTAINABLE LIGHTING SYSTEM WILL PRESENT A GREAT VISUAL EXPERIENCE THAT WILL HELP OUR CUSTOMERS STAY IN PEACE AND WONDER, EVEN IN THEIR PRIVATE HOTEL ROOM.



_BIOLUMINESCENCE MEDITATION

: SOUND FALLING WITH SUSTAINABLE LIGHT.

FOR THE MEDITATION ROOM PROVIDED FOR OUR VIP, WE PREPARED BIOLUMINESCENCE FALL INSTEAD OF WATER FALL. WITH THIS SYSTEM, OUR CUSTOMER COULD BE DEEPLY IMMERSED WITH THE INSIDE OF THEM.



VEHICLE CONCEPT

UNDERWATER VEHICLE / LAND VEHICLE

UNDERWATER VEHICLE / BUBBLE

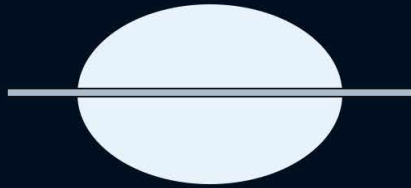

PROCESSING

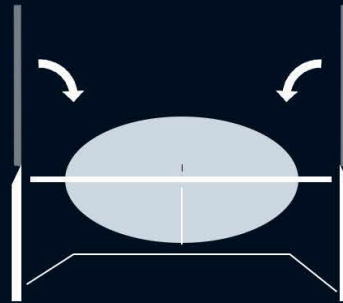
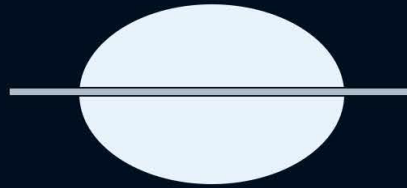

LAND VEHICLE / HALIOI

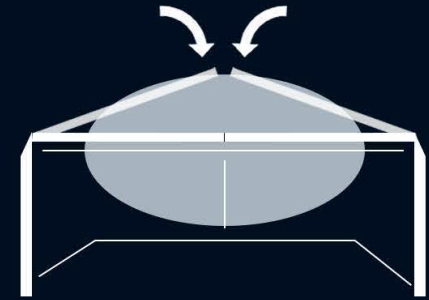

VEHICLE CONCEPT
U N D E R W A T E R
REIMAGINED UI/UX BETWEEN HUMANITY & OCEAN
LISTEN TO THEIR LIFE STORY

VEHICLE CONCEPT





Cadillac

OCEAN SYMPHONY

LUXURY OCEAN AUDITORY SYMPHONY BY OCEAN
ONLY FOR YOU



JELLYFISH & SQUID SKIN/STRUCTURE:

FOR THE JET PROPULSION IN THE REAR SIDE AND SPACE-EXTENDABLE STRUCTURE

: AUDITORY STRUCTURE



WATER FLOWS IN FOR JET PROPULSION

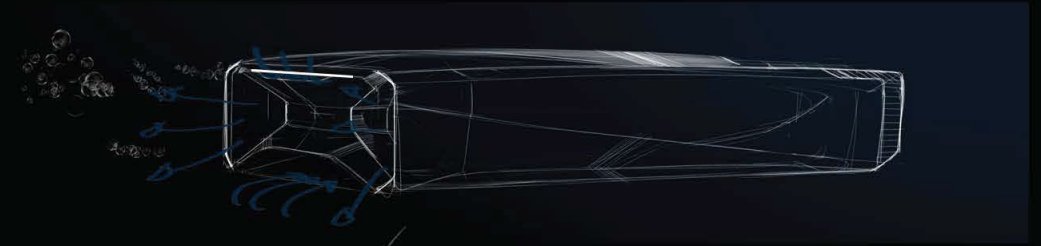

SQUID PROPELS ITSELF BY PULLING THE WATER IN AND COMPRESS IT MOMENTARILY

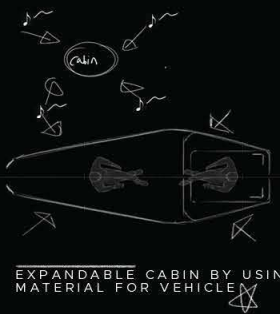

EXPANDABLE CABIN BY USING JELLYFISH MATERIAL FOR VEHICLE

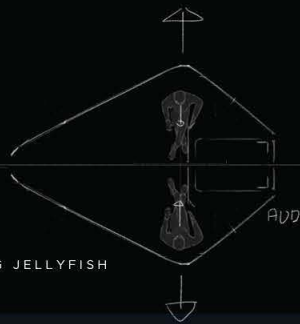

AUDITORY MODE



PROTECTED BY LIQUID JELLYFISH EXTERIOR LAY



WATER

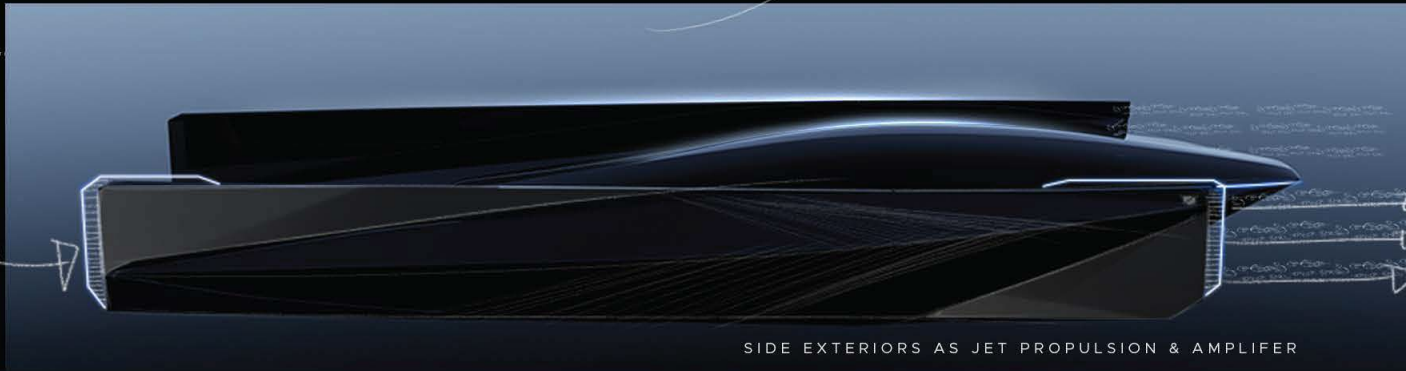

SIDE EXTERIORS AS JET PROPULSION & AMPLIFIER

ROTATING SIDE HEADSET: CUSTOMER: CAN CHOOSE BETWEEN TWO OPTIONS - VOYAGE MODE AND AUDITORIUM MODE

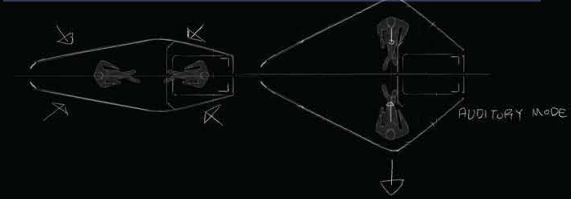
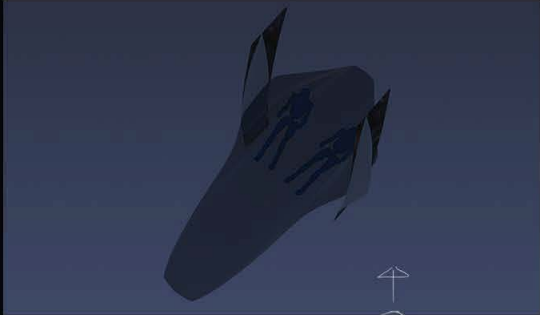

 AUDITORIUM MODE:
OUR CUSTOMER IS FULLY IMMERSERD WITH THE OCEAN SYMPHONY

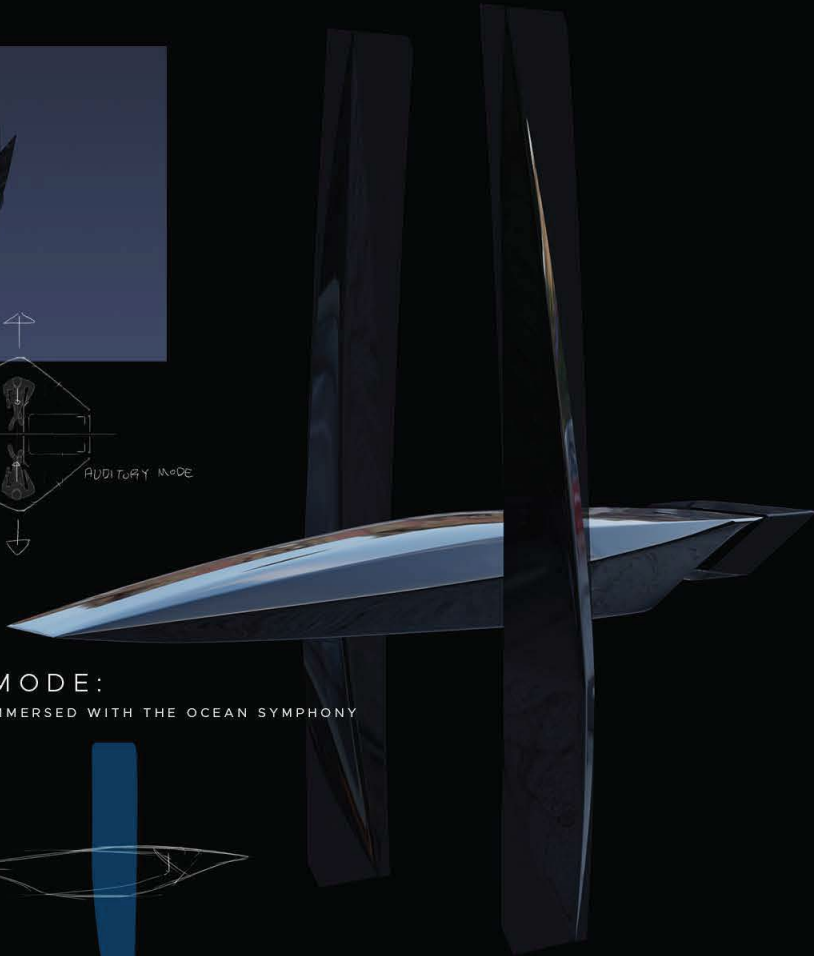
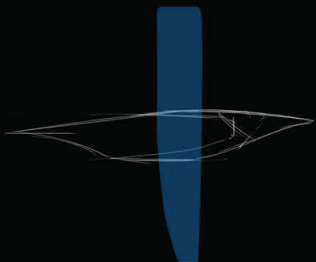

VOYAGE & ACTIVE ENGAGEMENT MODE: USING VR TECHNOLOGY, OUR CUSTOMER
CAN ACTIVELY ENGAGED IN THE OCEAN EXPLORATION.

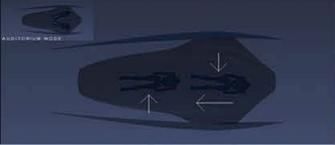

LIVING SURFACE: FILTRATION & AMPLIFICATION

FILLED WITH MILLIONS OF SENSORY NEURONS THAT HELP ORGANISM NAVIGATE ITS ENVIRONMENT

OCTOPUS SKIN



FILTRATION SYSTEM:

MAGNETIC FIELD AROUND THE MATERIAL WILL ABSORB TOXIC METAL PARTICLES TO PURIFY THE WATER

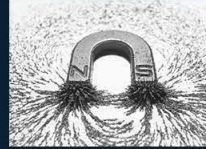

TOXIC METAL PARTICLE

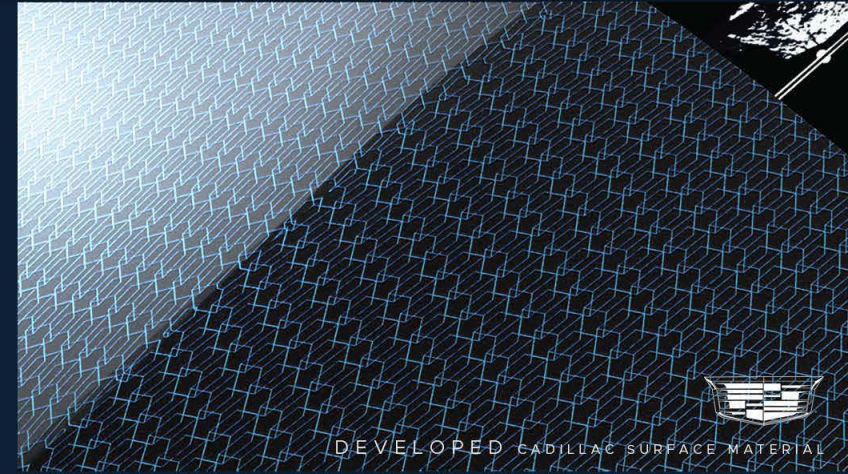

DEVELOPED CADILLAC SURFACE MATERIAL

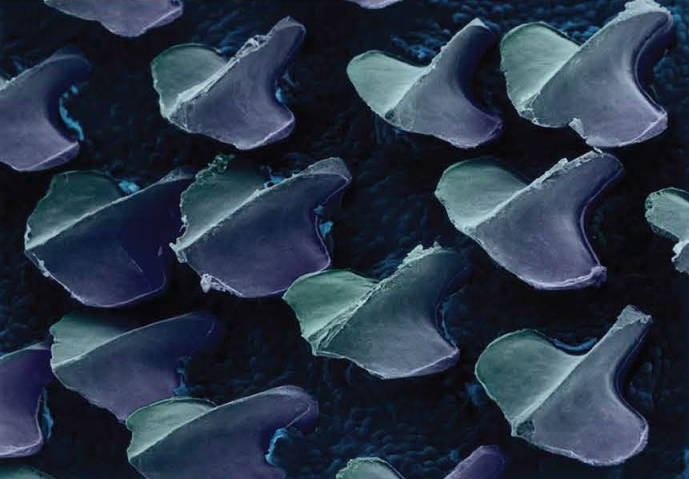

AMPLIFICATION SYSTEM:

EACH LIVING CELL EXPANDS THEIR SIZE AND AMPLIFY THE VOLUME VIBRATION RANGE FROM THE SEA CREATURE

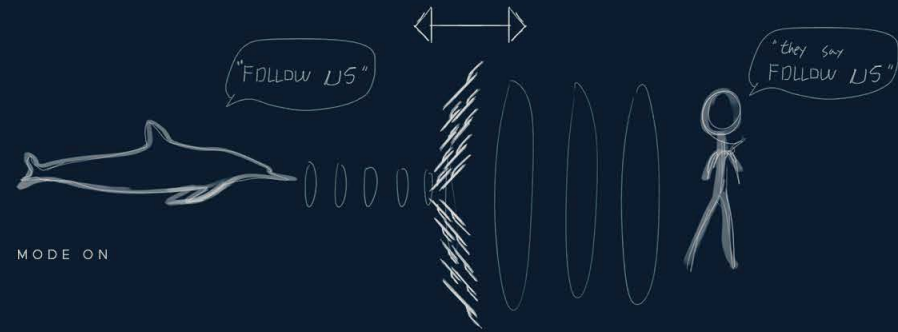

MODE ON

MODE OFF

EMPATHY BY CELL COLOR: OCTOPUS ACOUSTIC SKIN

OCTOPUS SKIN

WHEN THE CUSTOMER SITS INSIDE THE VEHICLE, OUR VEHICLE DETECTS THE CUSTOMER'S EMOTION AND SHOW HIM VEHICLE'S EMPATHY BY CHANGING THE ALIVE MATERIAL COLOR

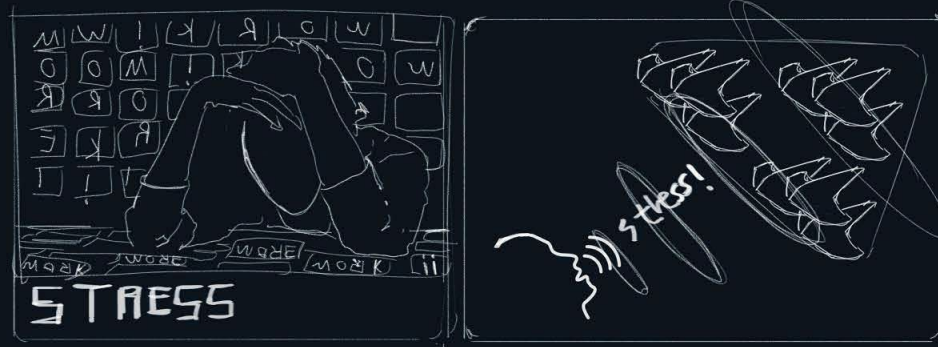

WARM ATMOSPHERE IS NEEDED FOR THE CUSTOMER!!!!

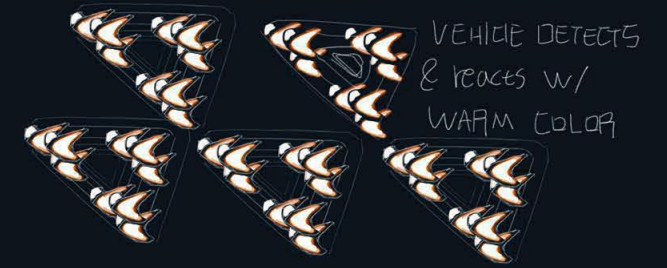

FANTASY ATMOSPHERE

WARM ATMOSPHERE



UNDER WATER : BUBBLE FORM + GYROSCOPE FRAME

NO MATTER WHAT SHAPE YOU HAVE, WHAT POSTURE YOU POSE, THIS BUBBLE CABIN MADE OUT OF JELLYFISH SKIN WILL HOLD YOU WITH ULTIMATE COMFORT

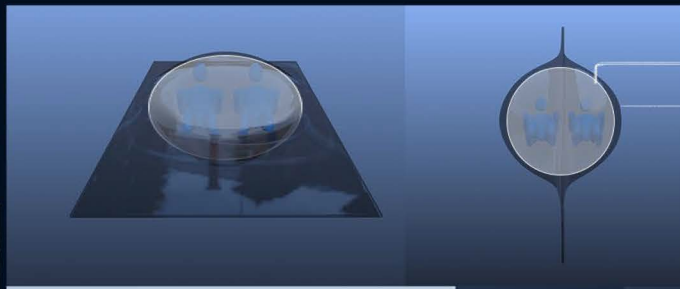
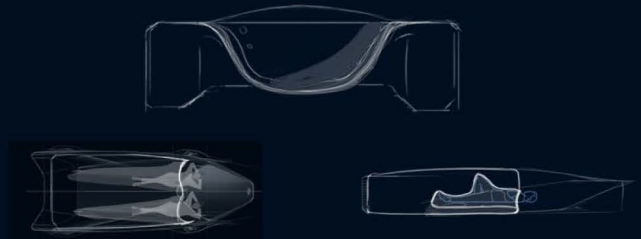
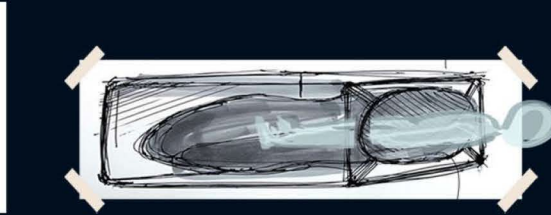
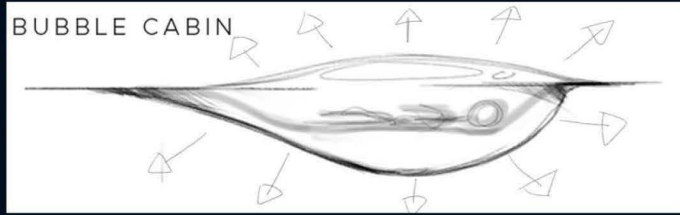

INNER LAYER IS STATIONARY
EXTERIOR FRAME IS ROTATABLE.

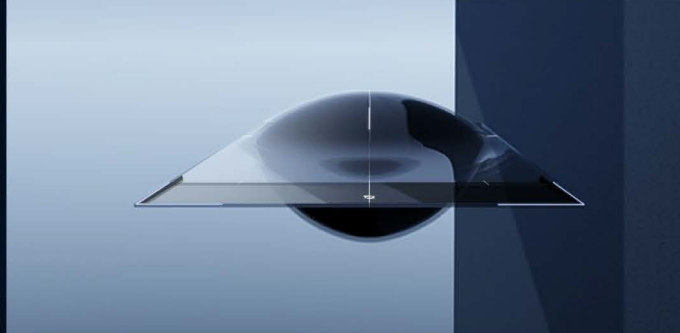

Cadillac.

JELLY FISH MATERIAL
USING JELLY FISH SKIN ENABLE THE EXTREME FLEXIBILITY OF VEHICLE SPACE

_ EXPERIENCE MODE : AUDITORY & VISIONARY EXPERIENCE

IN EXPERIENCE MODE, THE BUBBLE WILL BE IN LOW SPEED ENABLING OUR CUSTOMERS TO HAVE MAXIMUM VISIONARY & AUDITORY EXPERIENCES WITH GRAND SEASCAPE AND MAGICAL SEA ANIMALS

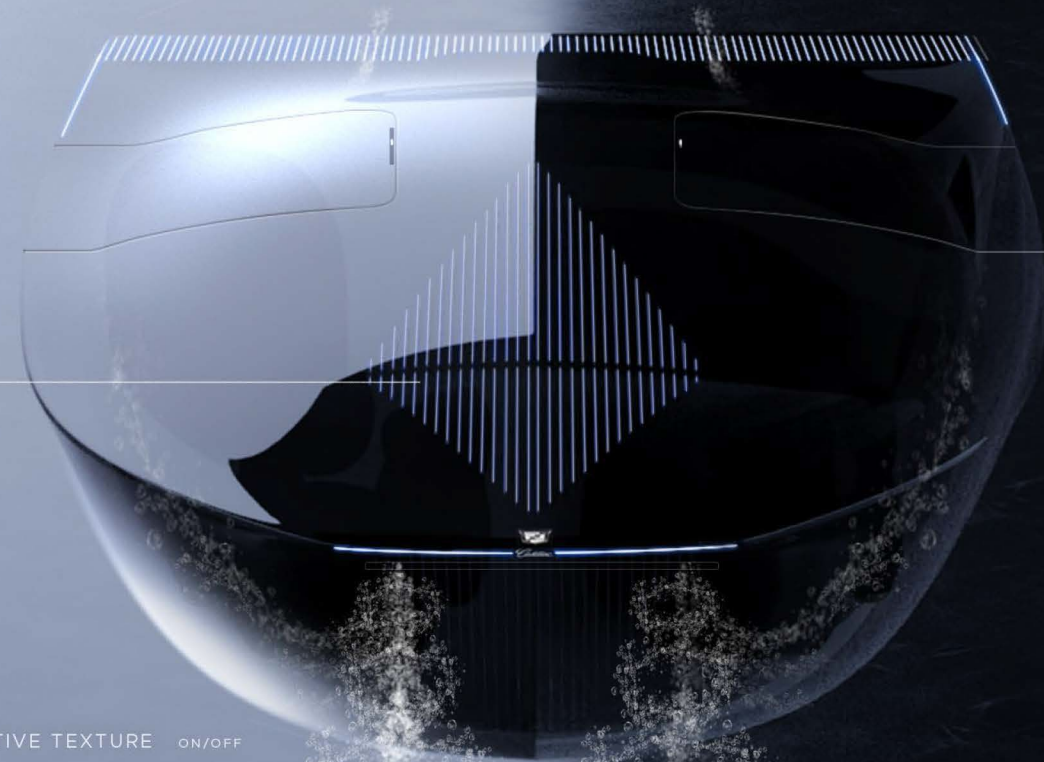

AUDITORY SUPORTIVE TEXTURE ON/OFF

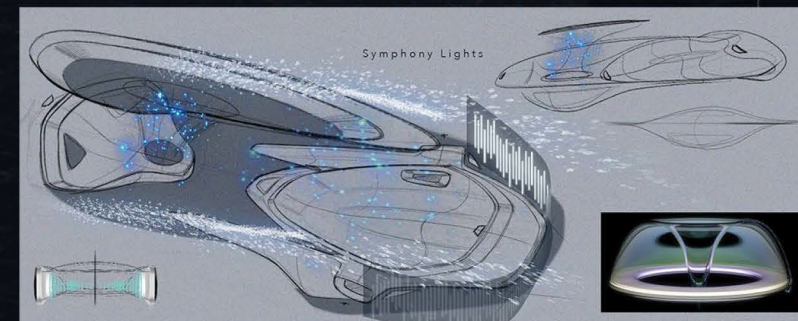

AUDITORY & VISIONARY EXPERIENCE



_HYPER VOYAGE MODE : JET PROPULSION

IN VOYAGE MODE, THE OUTER GYROSCOPE STRUCTURE ROTATES TO THE VERTICAL WHILE KEEPING THE INNER FUSELAGE SAME POSITION TO MAXIMIZE THE HYDRODYNAMIC IN THE WATER



_HYDRODYNAMIC & VERTICALITY: FIN STRUCTURE

IN THE DEEP WATER, VERTICALITY MATTERS MORE THAN WE EXPECT. THAT IS WHY MOST FISH IS LONGER IN VERTICAL WAY WITH A FIN HELPING THEM BALANCING IN THE WATER.

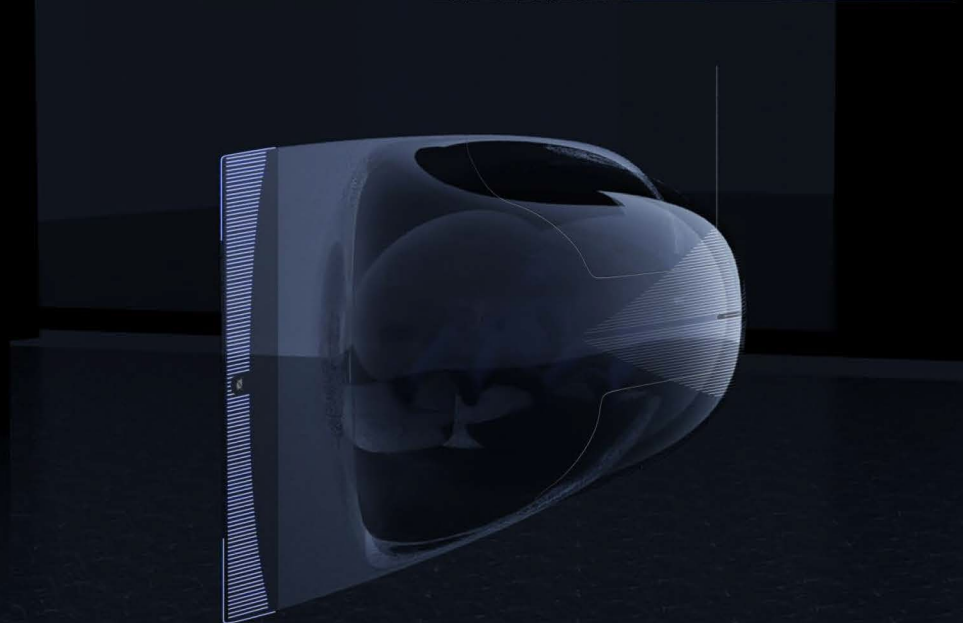

RE-IMAGINED LUXURY
MULTI-SENSORY EXPERIENCE

O C E A N S Y M P H O N Y





HUMANITY IS A PART OF NATURE
C A D I L L A C H A L I O I



ATLANTIS
BEYOND EXPLORATION FOR AN ANCIENT LEGACY
CADILLAC HALIOI



REIMAGINED LIFE IN THE REIMAGINED WORLD
C A D I L L A C H A L I O I

PURIFICATION

POLLUTED WATER BY TOXIC METAL PARTICLE

PURIFIED WATER

MAGNETIC FILTER



JET PROPULSION SYSTEM

USING SQUID STRUCTURE, WATER COMES THROUGH THE FRONT ENTRANCE AND IT IS COMPRESSED IN THE GAP BETWEEN THE TWO LAYERS AND COMES OUT. THIS PROCESS WILL KEEP GENERATING SUSTAINABLE CLEAN ENERGY.

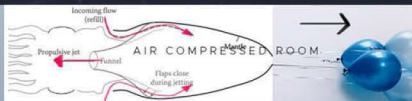

MOVEMENT OF WATER THROUGH INNER PASSAGE



THE GAP BETWEEN TWO LAYERS FOR WATER PASSAGE

FRONT ENTRANCE & REAR EXHAUST



CIRCULATION

BIOLUMINESCENT STARLIGHT

BIOLUMINESCENT PLANKTONS PASS THROUGH THE CABIN, PROVIDING AN IMMERSIVE LIGHT EXPERIENCE. THE PLANKTONS ACTIVATE THE BLUE LIGHTS WHEN IT SENSES MOVEMENT IN WATER.



SUSTAINABLE LIGHT SOURCE

ONCE THE LAND VEHICLE IS ASSEMBLED WITH THE BUBBLE, THE BIOLUMINESCENCE WILL FLOW THROUGH THE PASSAGES INSIDE THE LAND VEHICLE, WHICH BECOMES A SUSTAINABLE AND CLEAN LIGHT ENERGY SOURCE.



AIR JET PROPULSION ROOM

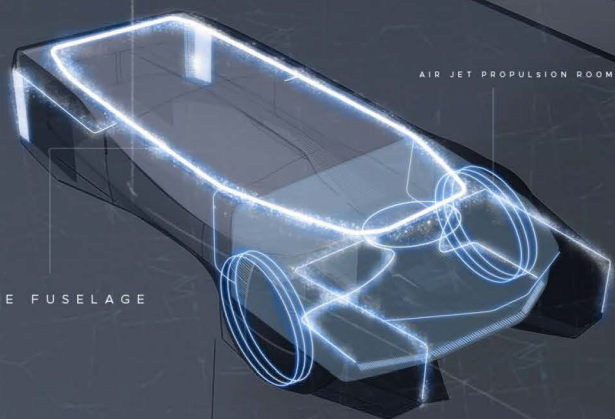

BUBBLE FUSELAGE

INTERIOR CONCEPT

IMMERSIVE AUDITORIUM



_CABIN KEY SKETCH

WHILE THE OVERALL BUBBLE FUSELAGE STAYS COMPLETELY ORGANIC, THE INTERIOR SPACE PROVIDES A VICE-VERSA EXPERIENCE. THE INTERIOR PROVIDES A FULLY IMMERSIVE CABIN FOR THE USERS TO RELAX MEDITATE OR FOCUS ON ACOUSTIC STUDIES.

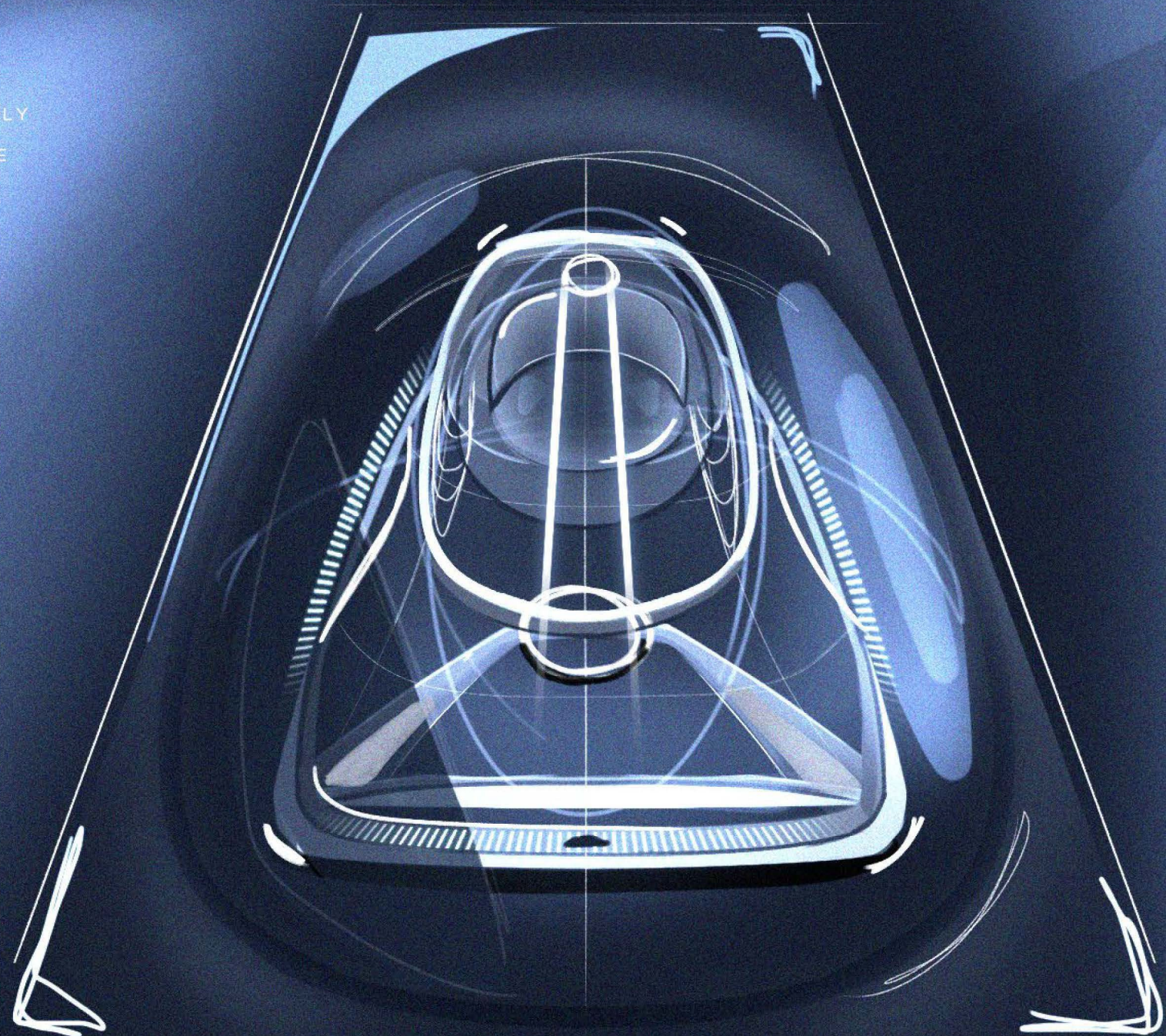

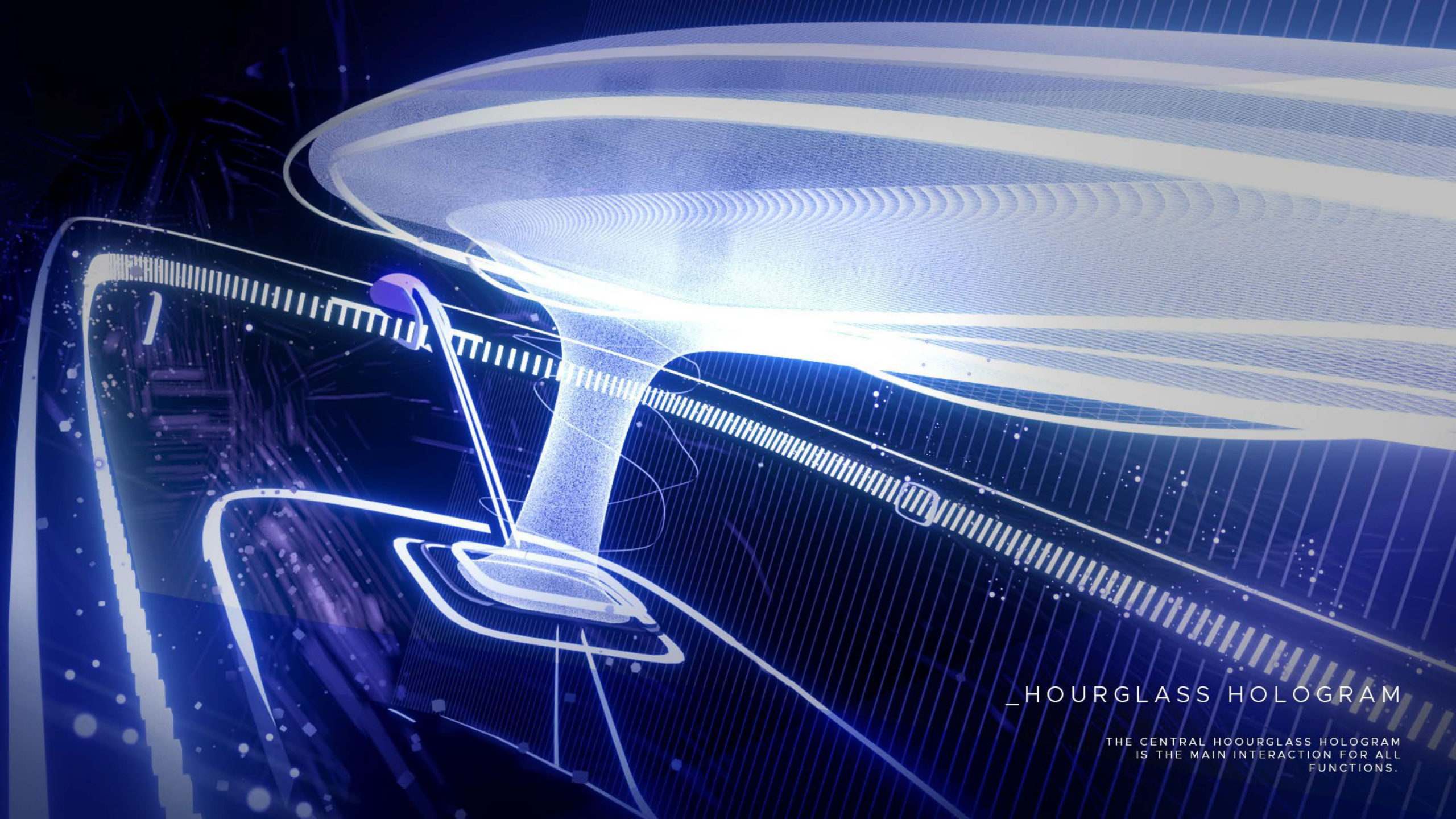

_HOURGLASS HOLOGRAM

THE CENTRAL HOOURGLASS HOLOGRAM
IS THE MAIN INTERACTION FOR ALL
FUNCTIONS.

_INTERIOR SPACE

THE INTERIOR CONSISTS OF MAGLEV PIECES, EACH INDIVIDUAL PIECES ACT AS ACOUSTIC BARRIERS, WHICH IS THE TECHNOLOGY USED IN THE AUDITORIUMS TO BETTER REFLECT THE AUDITORY EXPERIENCE.

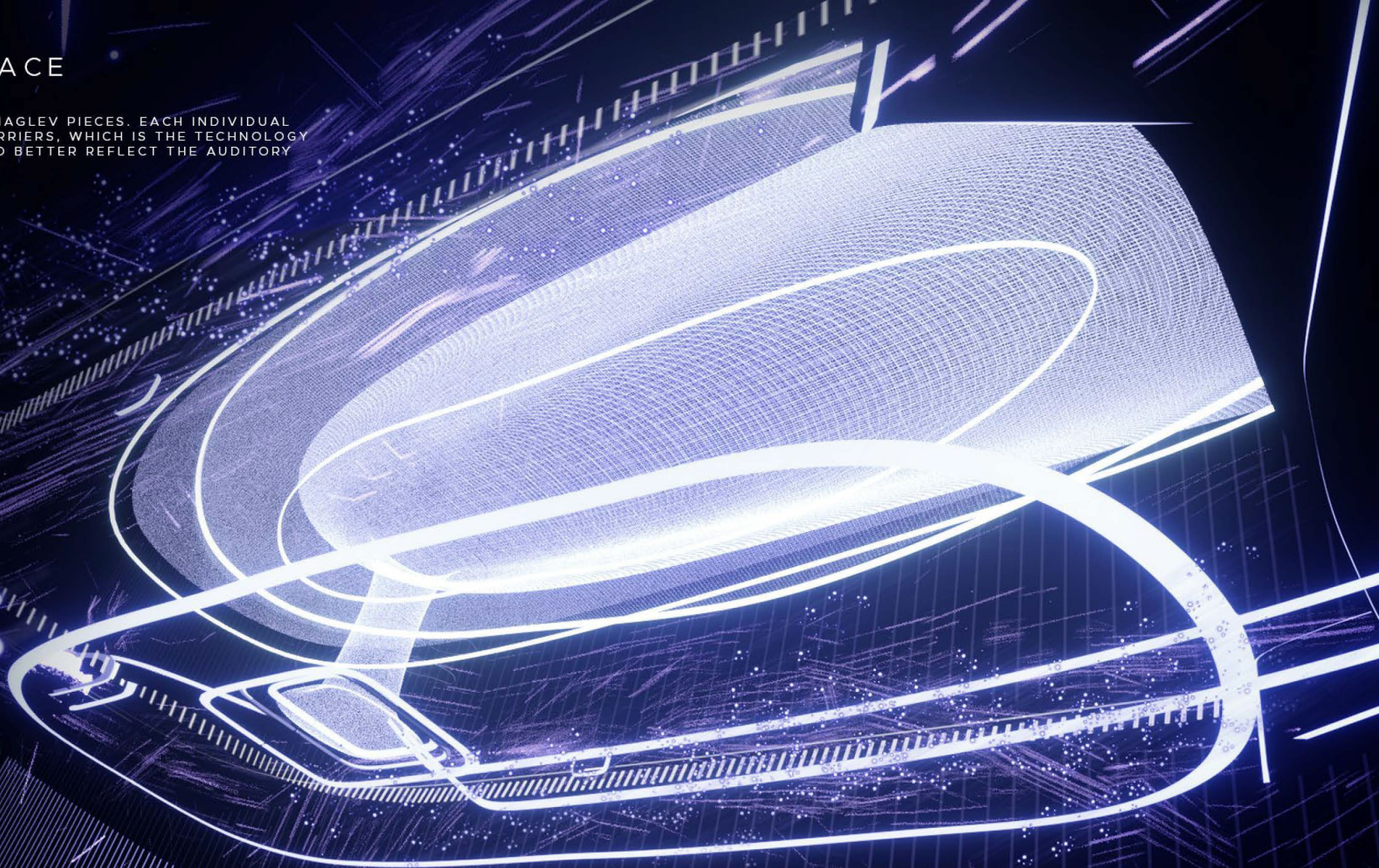

_IMMERSIVE HOLOGRAM

THE CENTRAL HOURLASS HOLOGRAM EMITS HOLOGRAPHIC DISPLAYS TO PROVIDE A MORE IMMERSIVE VISUALIZATION FOR THE USERS.

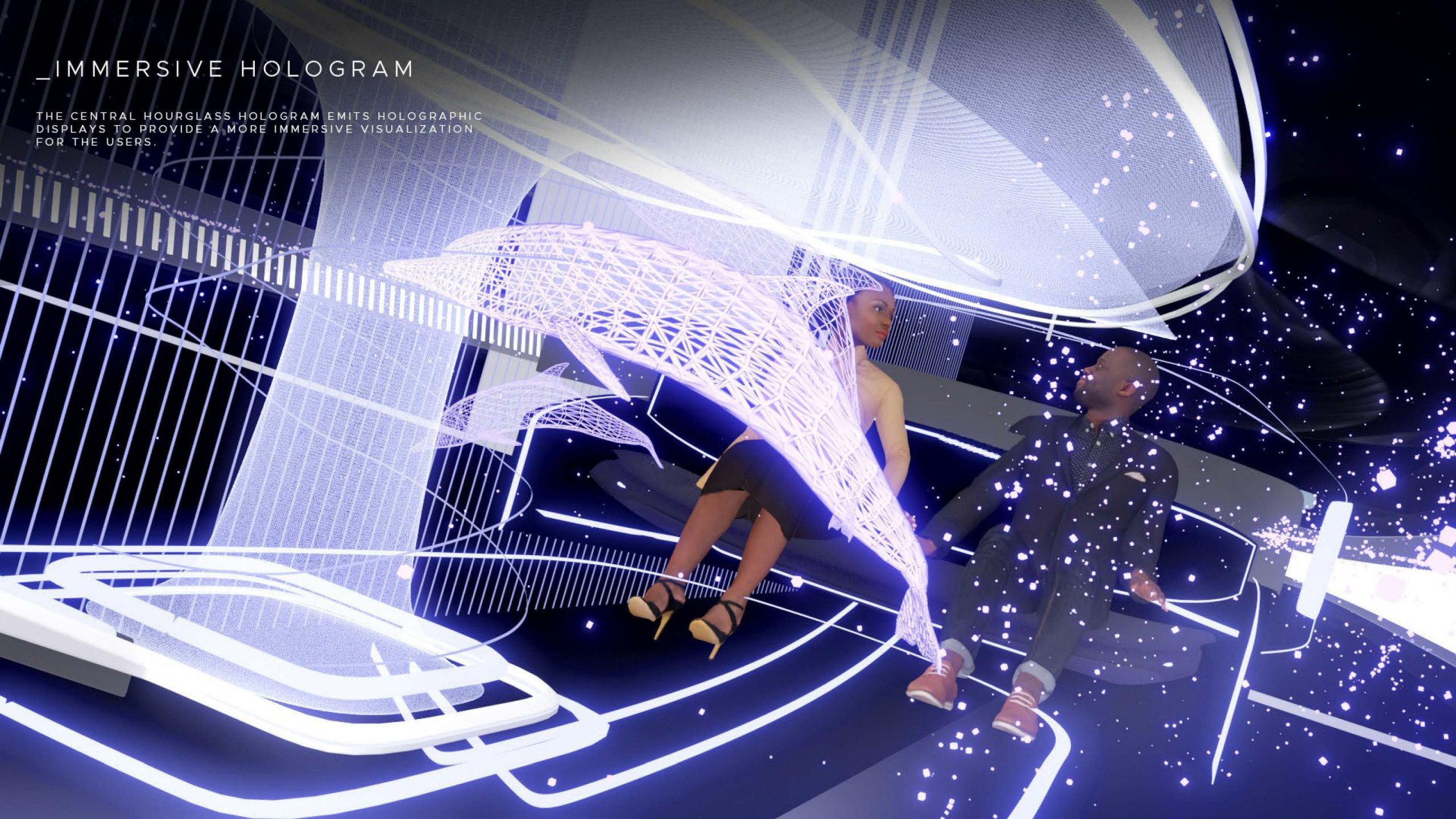

_CADILLAC COMPRESSION CONTROL DOOR

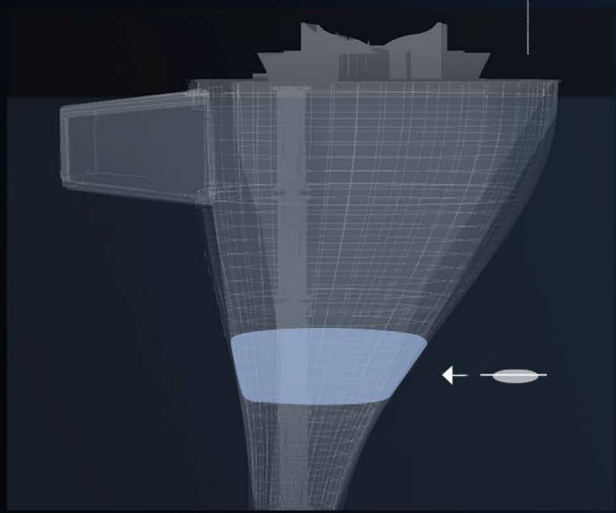

_SPECIAL ENTRANCE : UNDERWATER PARKING LOUNGE FOR VIP

BESIDE ABOVE WATER PARKING LOUNGE, WE OFFER ONE MORE SPECIAL ENTRANCE ONLY FOR OUR VIP CUSTOMERS. THIS ENTRANCE IS DIRECTLY CONNECTED WITH OUR CUSTOMER'S PENTHOUSE



_MAG-LEV CHARGING RAIL



_HALIOI DOCKING LOUNGE

: UNDERWATER PARKING LOUNGE FOR VIP

BESIDE ABOVE WATER PARKING LOUNGE, WE OFFER ONE MORE SPECIAL ENTRANCE ONLY FOR OUR VIP CUSTOMERS. THIS ENTRANCE IS DIRECTLY CONNECTED WITH OUR CUSTOMER'S PENTHOUSE

-1
CADILLAC DOCKING LOUNGE

CUSTOMER
DEJA
JORDAN

CHARGING STATUS
56%

DESTINATION
PARIS





HALIOI DOCKING LOUNGE
DEJA
JORDAN
56%
PARIS

1
WHERE TO GO

_ HALIOI DOCKING LOUNGE

: UNDERWATER PARKING LOUNGE FOR VIP

BESIDE ABOVE WATER PARKING LOUNGE, WE OFFER ONE MORE SPECIAL ENTRANCE ONLY FOR OUR VIP CUSTOMERS. THIS ENTRANCE IS DIRECTLY CONNECTED WITH OUR CUSTOMER'S PENTHOUSE

PARIS
2030
MADRID



1

CADILLAC DOCKING LOUNGE

DESTINATION SETTING

WHERE TO GO?

VEHICLE TYPE

Land

Water

CHARGING STATUS

85%

VEHICLE CONTROL
EXPERIENCE SETTING

_HALIOI DOCKING LOUNGE

: UNDERWATER PARKING LOUNGE FOR VIP

BESIDE ABOVE WATER PARKING LOUNGE, WE OFFER ONE MORE SPECIAL ENTRANCE ONLY FOR OUR VIP CUSTOMERS. THIS ENTRANCE IS DIRECTLY CONNECTED WITH OUR CUSTOMER'S PENTHOUSE



MAGNETIC RAIL ACTIVATED



OPEN/CLOSE

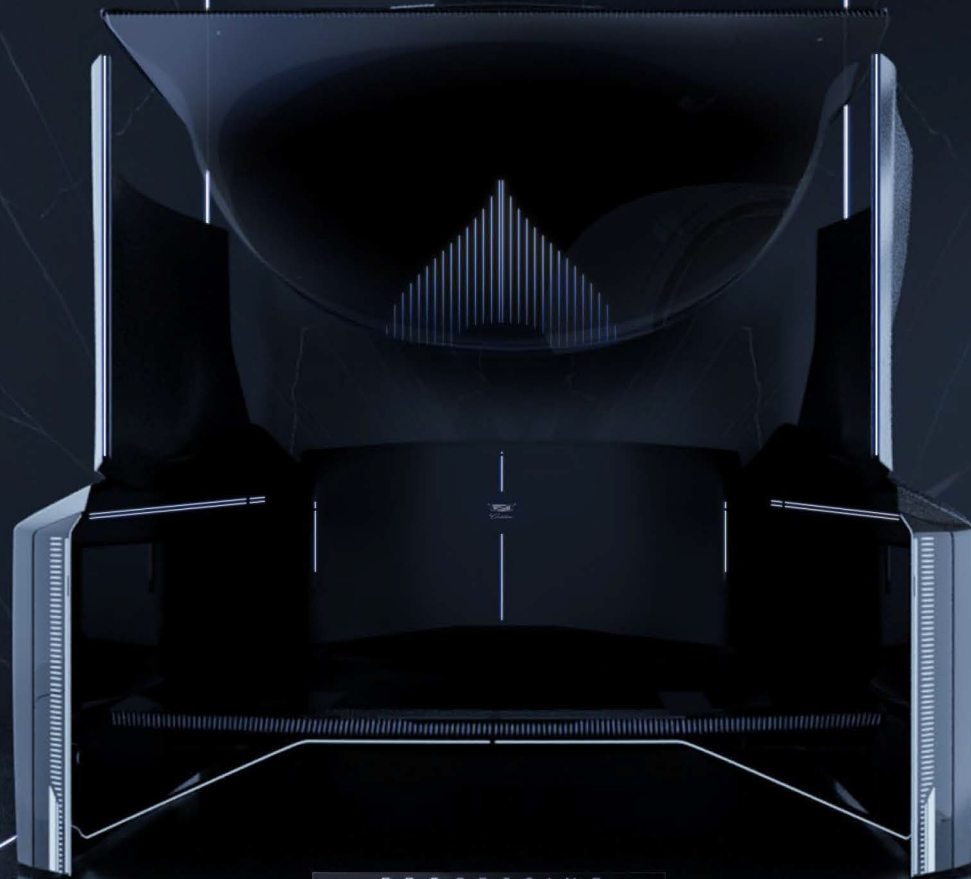
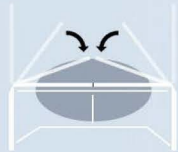
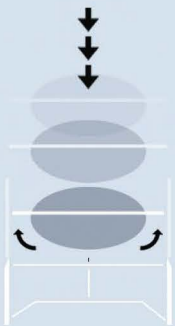

PROCESSING

_ MAGNETIC DOCKING LOUNGE

: UNDERWATER PARKING LOUNGE FOR VIP

BESIDE ABOVE WATER PARKING LOUNGE, WE OFFER ONE MORE SPECIAL ENTRANCE ONLY FOR OUR VIP CUSTOMERS. THIS ENTRANCE IS DIRECTLY CONNECTED WITH OUR CUSTOMER'S PENTHOUSE



_ MAGNETIC DOCKING LOUNGE

: UNDERWATER PARKING LOUNGE FOR VIP

BESIDE ABOVE WATER PARKING LOUNGE, WE OFFER ONE MORE SPECIAL ENTRANCE ONLY FOR OUR VIP CUSTOMERS. THIS ENTRANCE IS DIRECTLY CONNECTED WITH OUR CUSTOMER'S PENTHOUSE



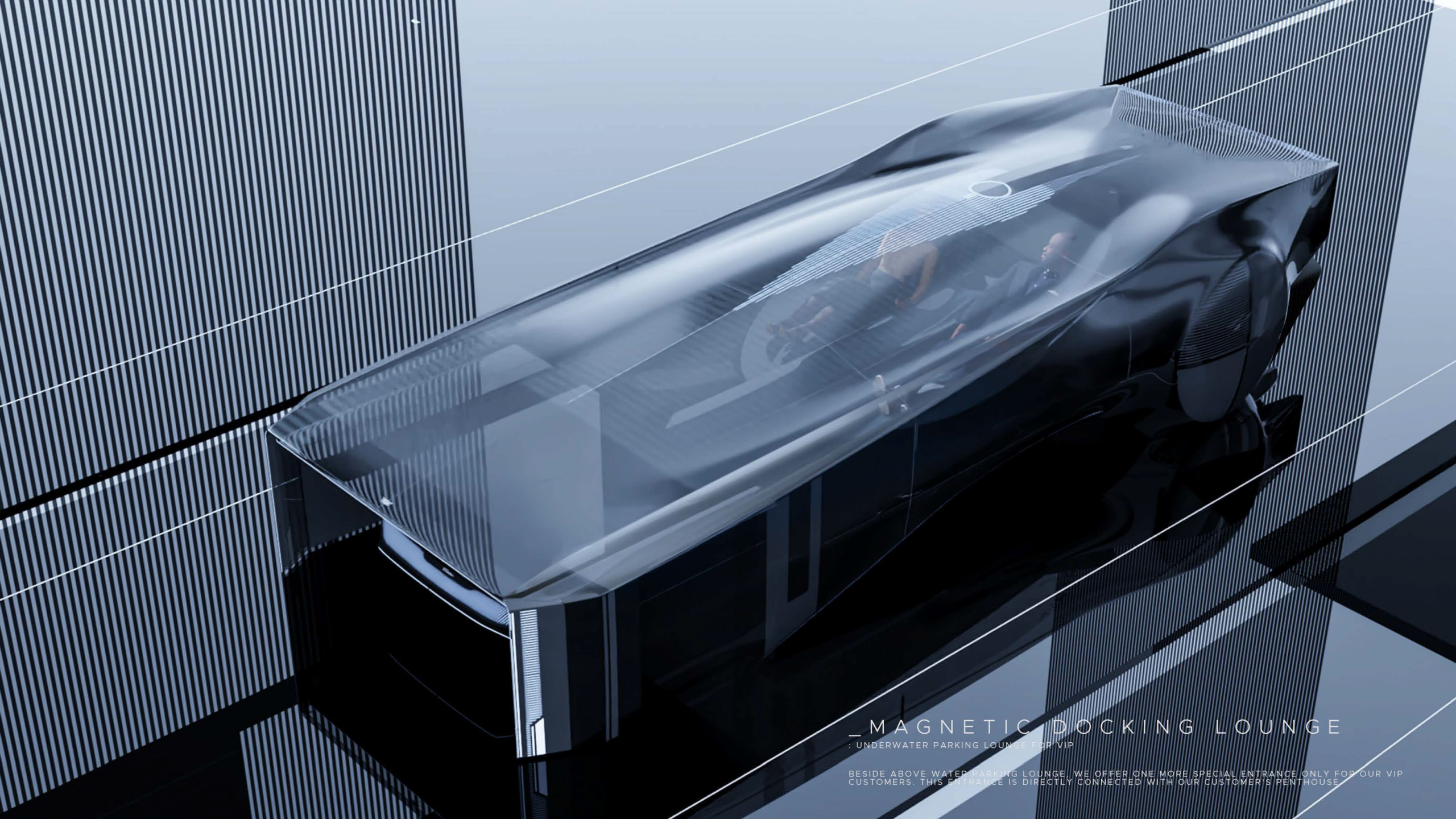

_ MAGNETIC DOCKING LOUNGE

: UNDERWATER PARKING LOUNGE FOR VIP

BESIDE ABOVE WATER PARKING LOUNGE, WE OFFER ONE MORE SPECIAL ENTRANCE ONLY FOR OUR VIP CUSTOMERS. THIS ENTRANCE IS DIRECTLY CONNECTED WITH OUR CUSTOMER'S PENTHOUSE

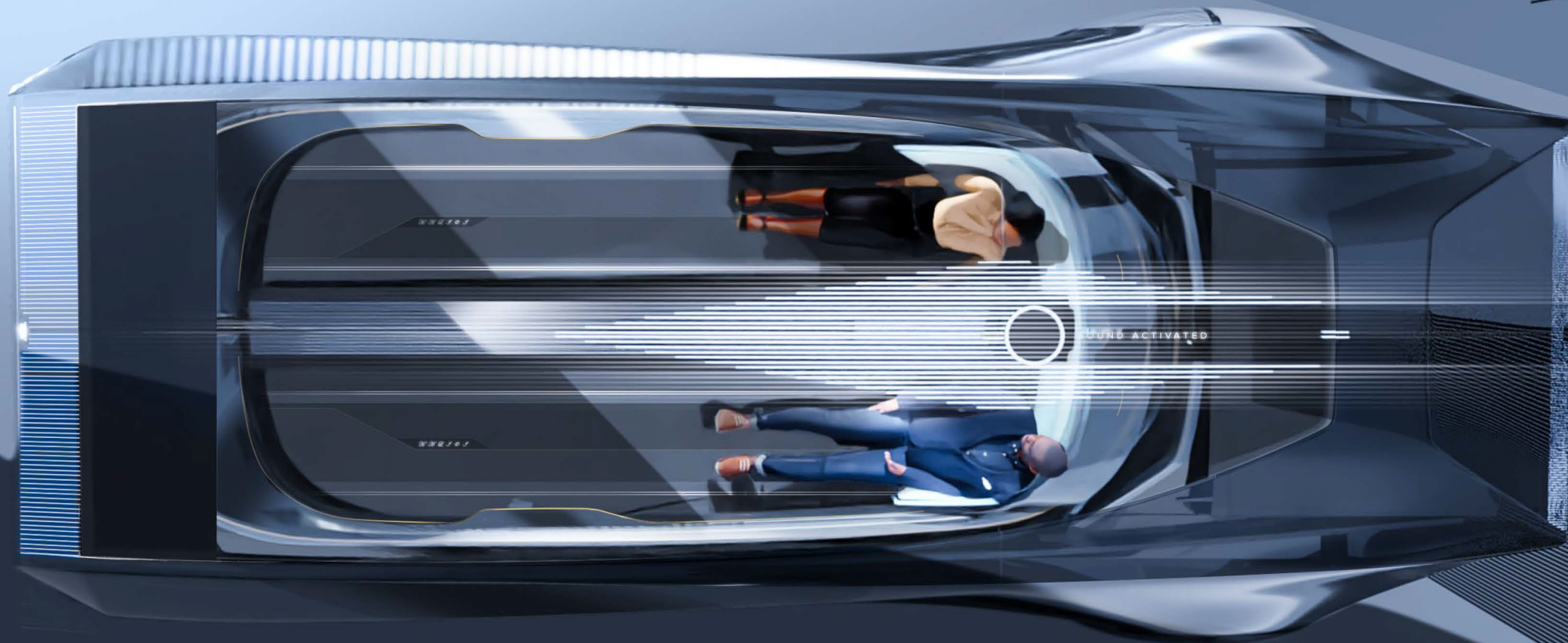

_ SOUND WAVE THERAPY

: SOUND FROM HALIOI UNDER WATER ANIMALS

SOUND ACTS CRUCIAL PART FOR HUMAN THERAPY IN EVERY DAILY LIFE. IT EASES OUR MIND AND BODY AND PROVIDE SMOOTH AND WARM ENVIRONMENT WHICH HELPS CUSTOMERS COMMUNICATE DEEPLY IN THE VEHICLE

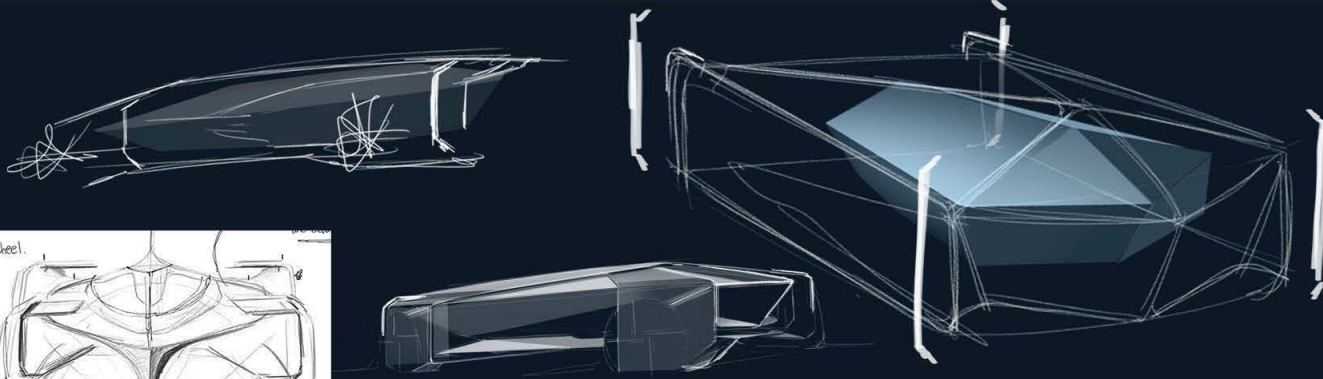
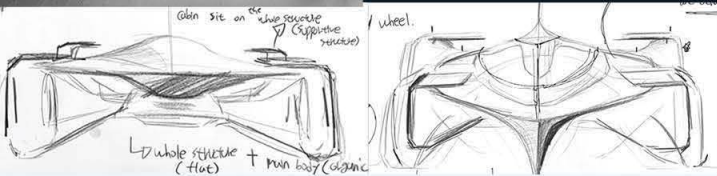

MAG. CHARGER
CHARGING WHILE THE CABIN AND THE EXTERIOR ATTACHED

CADILLAC DESIGN SKETCH



OPEN GLASS STRUCTURE

THE WHOLE BROAD OCEAN IS YOUR HOME AND WE WANT TO PRESENT THIS WHOLE VIEW TO YOU AT ANYTIME.

VEHICLE CONCEPT



MAGNETIC PARTICLE FILTRATION

BECAUSE OF HUMAN'S IMMORAL AND IRRESPONSIBLE BEHAVIOUR FOR THE PAST HUNDREDS OF YEARS, MOST OF OCEAN IS CONTAMINATED WITH ESPECIALLY TOXIC METAL PARTICLES.

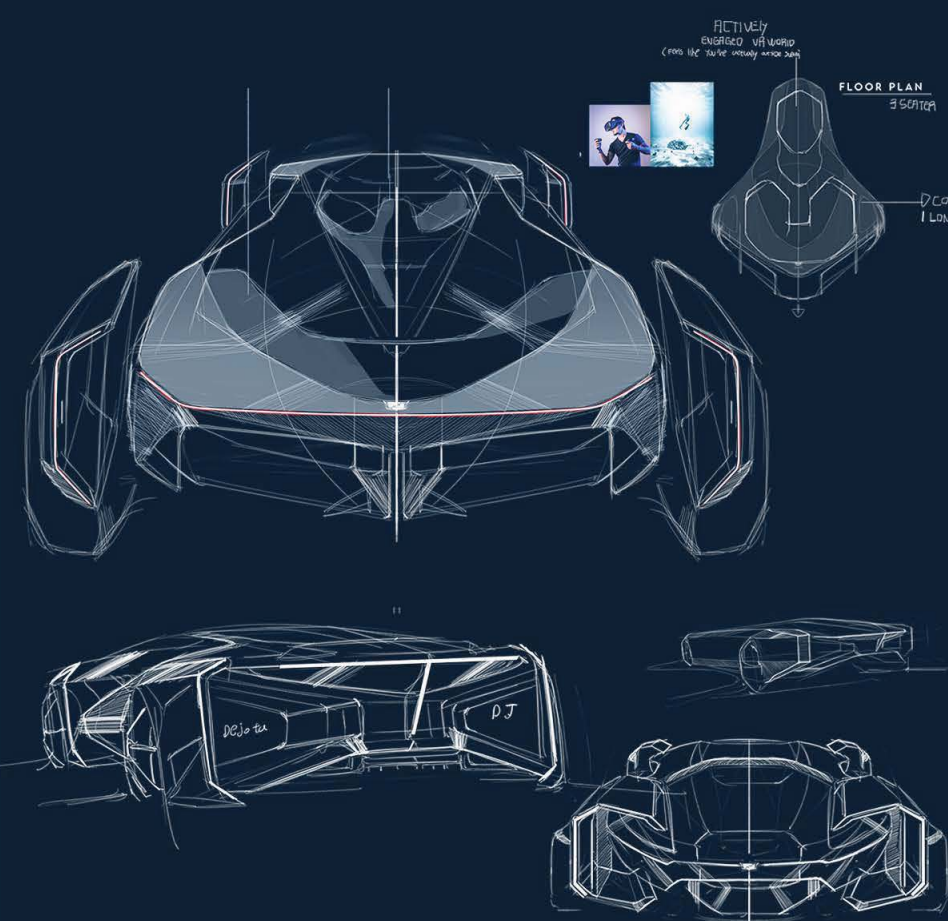
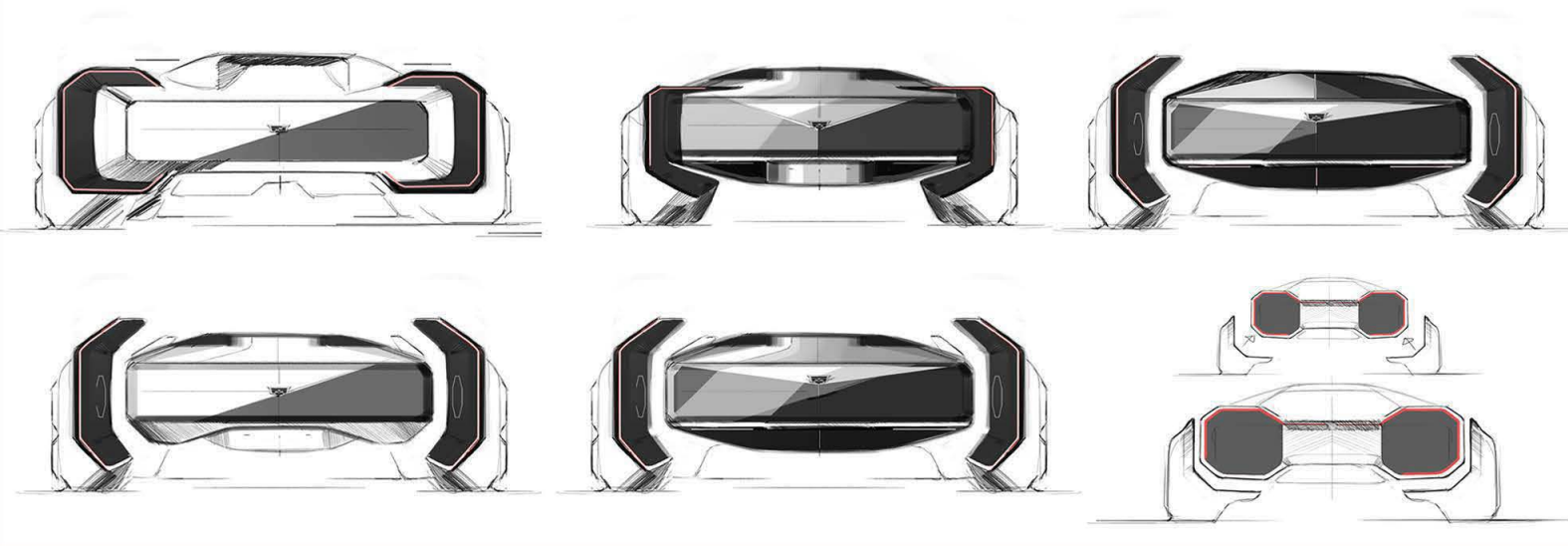
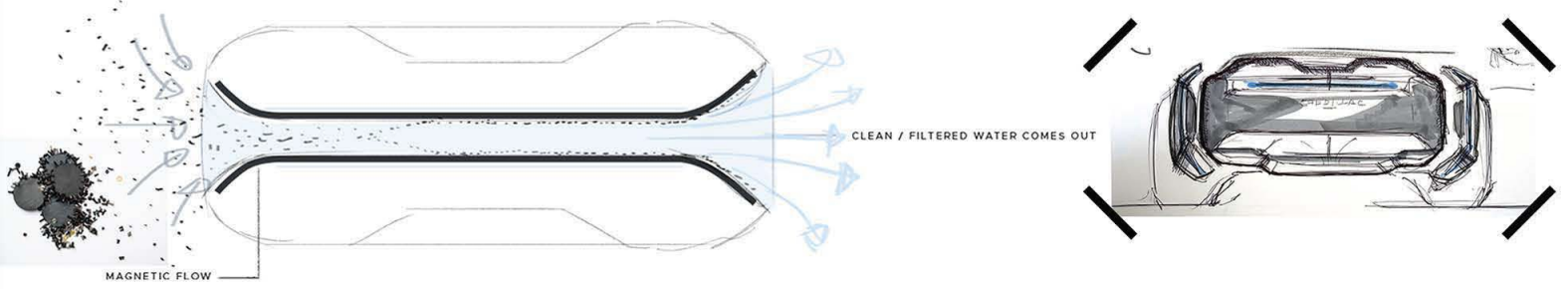

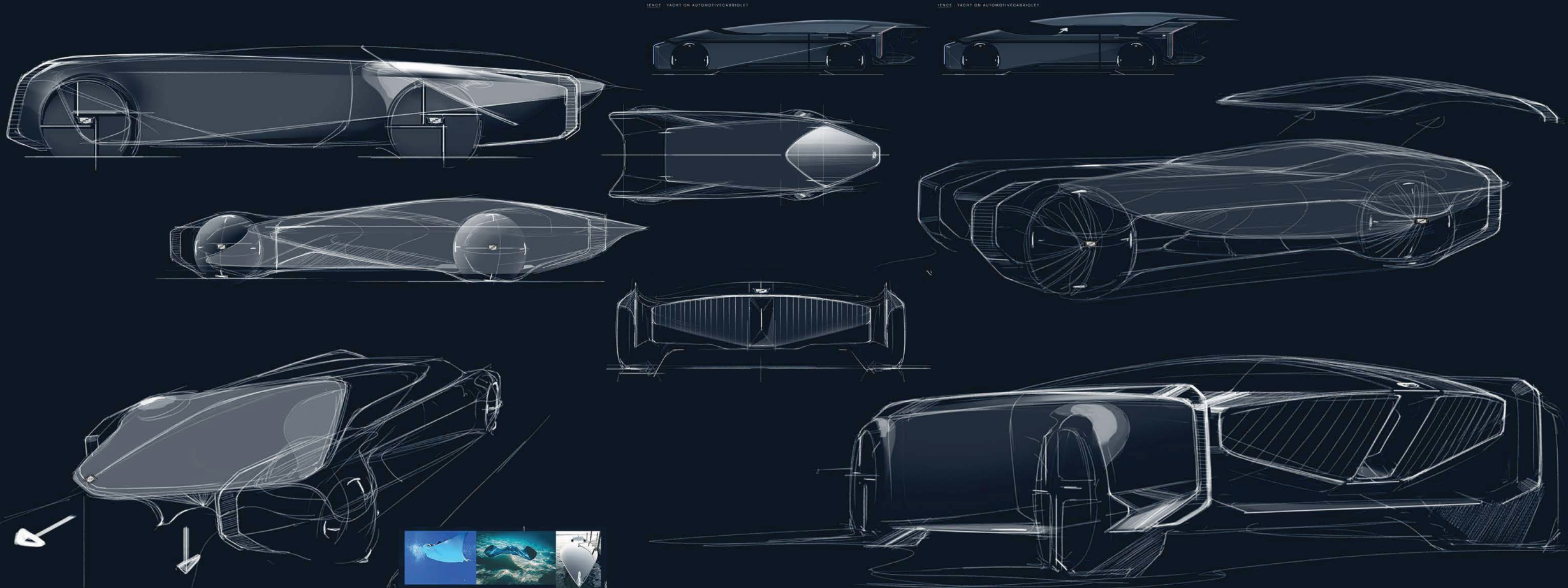

IENCE YACHT ON AUTOMOTIVE CABRIOLET

IENCE YACHT ON AUTOMOTIVE CABRIOLET



STRINGRAY
ORGANIC OVERALL FORM • SHARP TAIL • ORGANIC • GEOMETRIC DESIGN LANGUAGE

SQUID STRUCTURE & AIR JET PROPULSION: JUST LIKE THE JET
PROPULSION SYSTEM UNDER THE WATER, WE HAVE SAME SYSTEM ABOVE WATER USING AIR WHICH IS 100% CLEAN.

EXTERIOR STRUCTURE

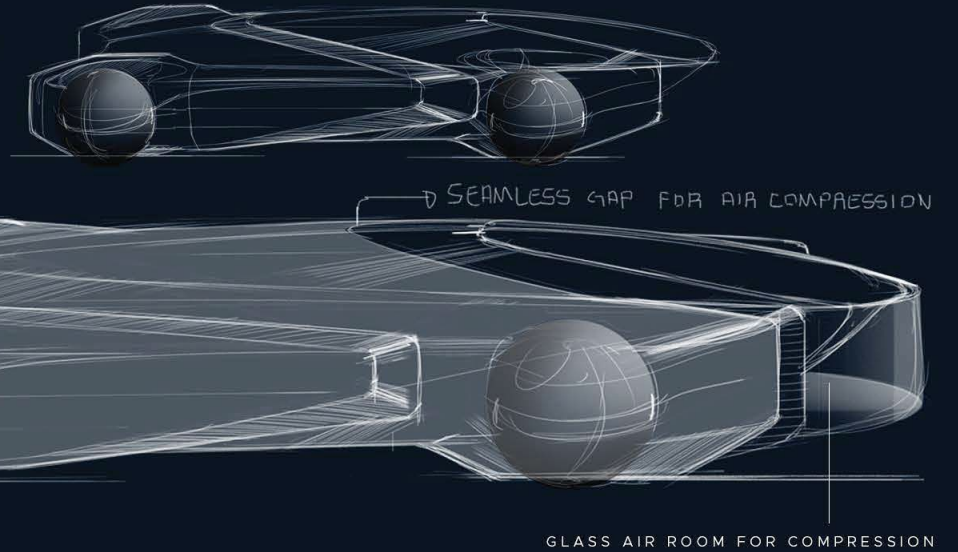
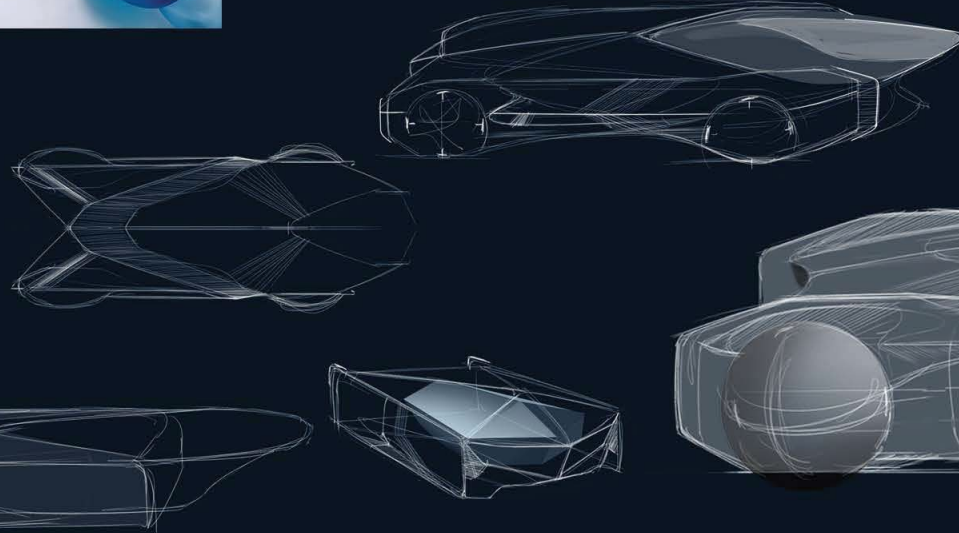
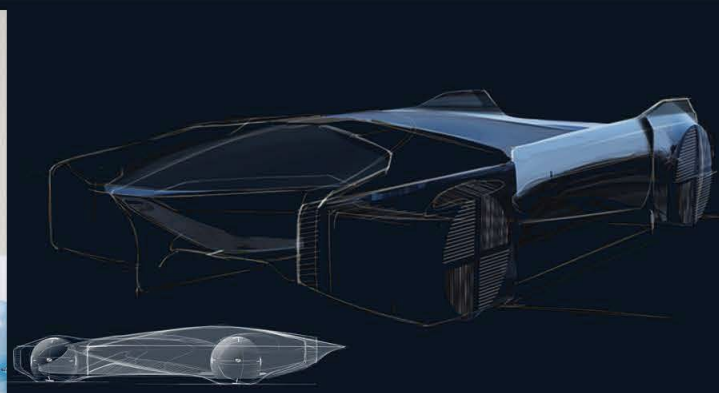

IMMERSIVE EXPERIENCE EVEN ABOVE THE WATER

BY HAVING EXTENDED SIDE WINDOW ON THE SIDE SURFACE, OUR CUSTOMER COULD FEEL IMMERSIVE DEEPLY AS IT IS UNDER THE WATER EXPERIENCE WHICH HELPS OUR CUSTOMERS BE IN EXOTIC BUT HIGH QUALITY REST.



SPACE CONTROL_ BUBBLE CABIN



JET PROPULSION COMP/ EXHAUST ROOM

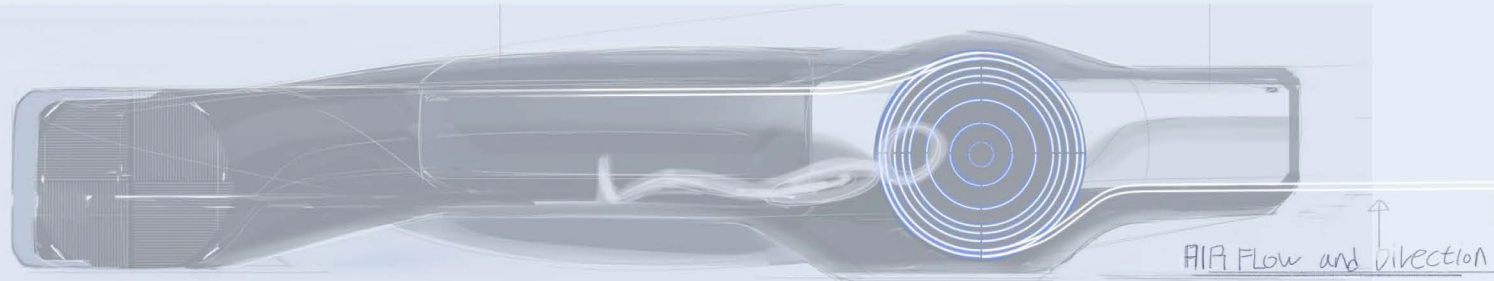

AIR Flow and Direction

IMMERSIVE SOUND THERAPY USING AUDITORY SENSE & SOUND WAVE FROM DOLPHINS

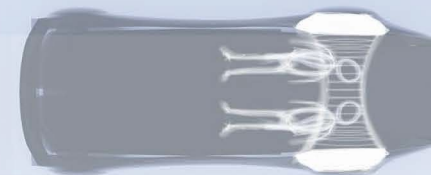
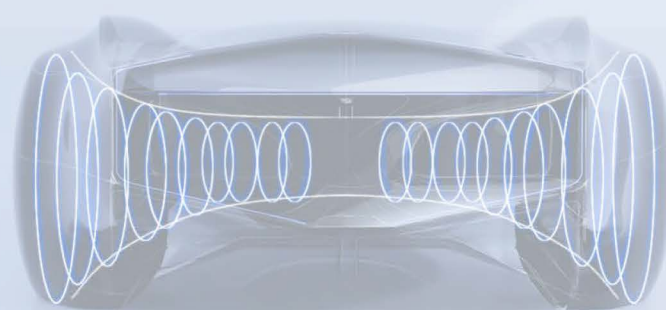

SIDE DESIGN DEVELOPMENT

THE ENTIRE FUSELAGE IS MADE OUT OF LIQUID MATERIAL. THEREFORE, OUR OBJECTIVE FOR FRONT IS TO COME UP WITH A PROTECTIVE AND MACHINERY DESIGN CONSIDERING THE ENTRANCE AT THE FRONT

PLATIN

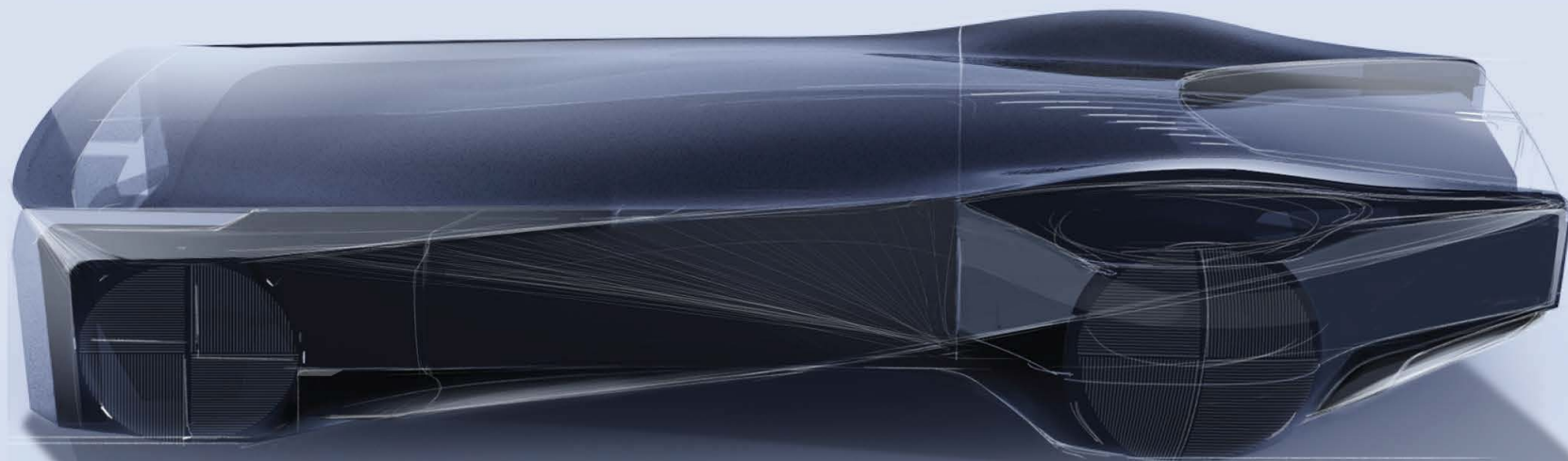
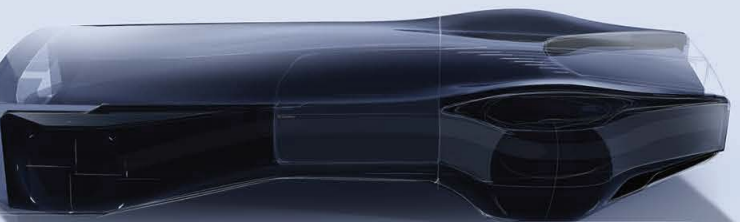

FRONT DEVELOPMENT

THE ENTIRE FUSELAGE IS MADE OUT OF LIQUID MATERIAL. THEREFORE, OUR OBJECTIVE FOR FRONT IS TO COME UP WITH A PROTECTIVE AND MACHINERY DESIGN CONSIDERING THE ENTRANCE AT THE FRONT

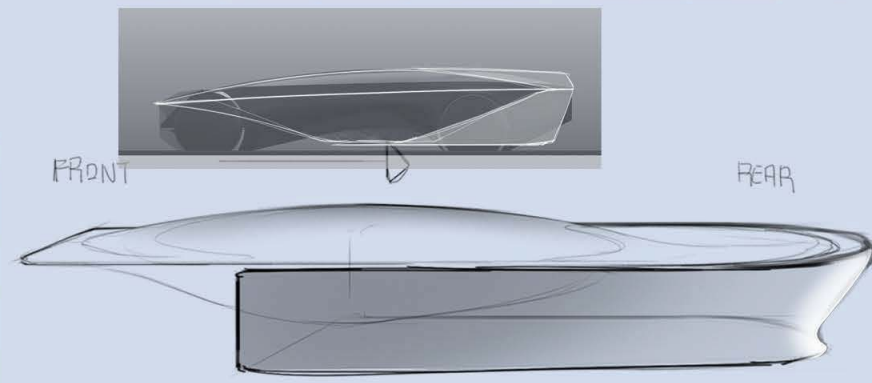
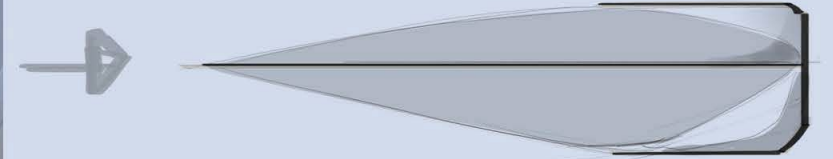
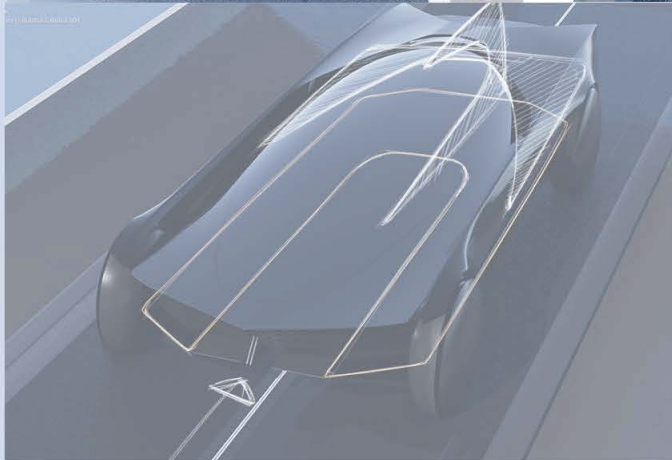
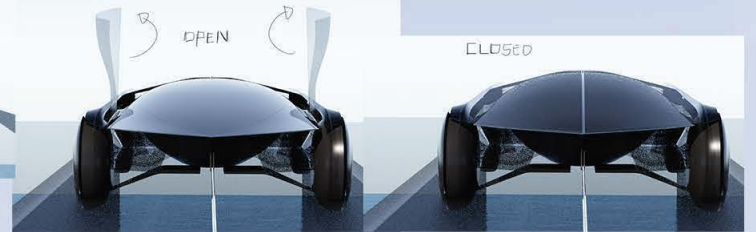

REAR DEVELOPMENT:

THE PURPOSE OF THE REAR DESIGN IS TO SHOW NEW AND MODERN DESIGN WITH THE ORGANIC GRAPHIC FROM OCEAN AND ARCHITECTURAL FORM AROUND IT FROM CADILLAC BRAND

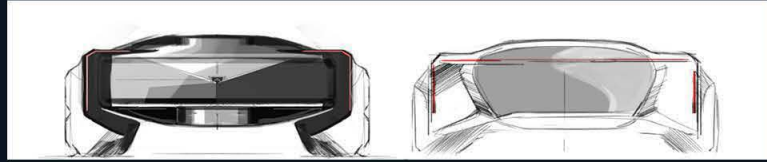

SEAMLESS FOR AIR COMPRESSION (FOR AIR JET PROPULSION)

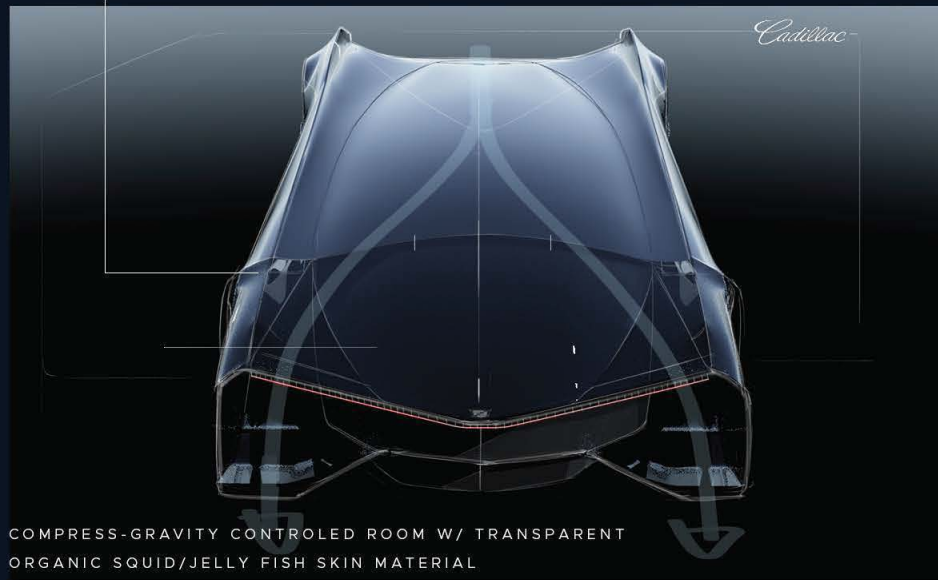

STRUCTURE DEVELOPMENT

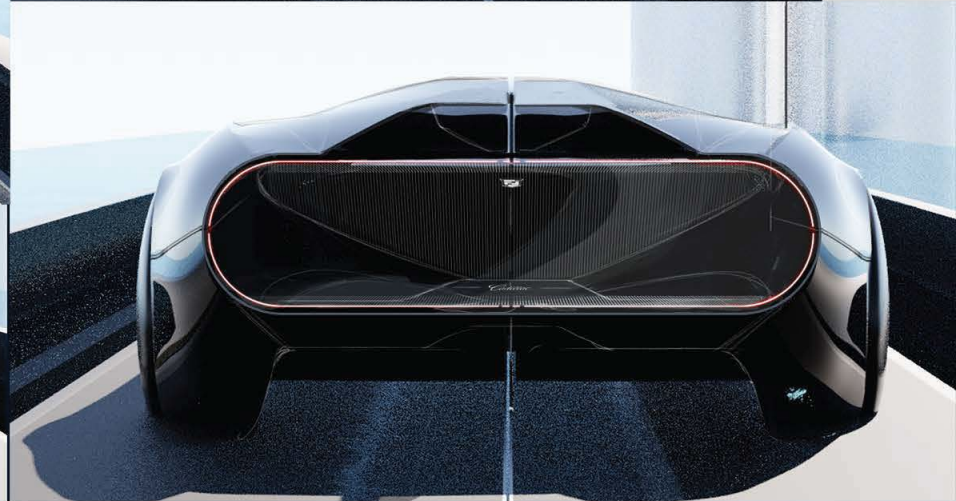
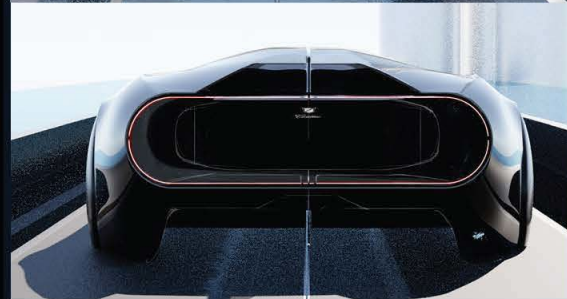
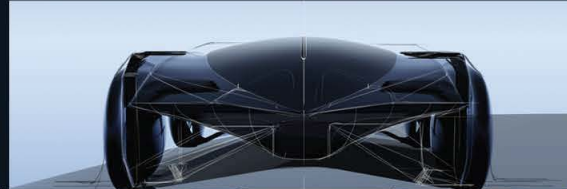

SOUND CREATION STRUCTURE_HOUR GLASS

IN ORDER FOR THE SOUND TO BE CREATED AND AMPLIFIED, THERE SHOULD BE PROPER SIZE OF ORGANIC SPACE . IN HALTOL, WE ACHIEVE THAT BY HAVING HOURGLASS FORM.

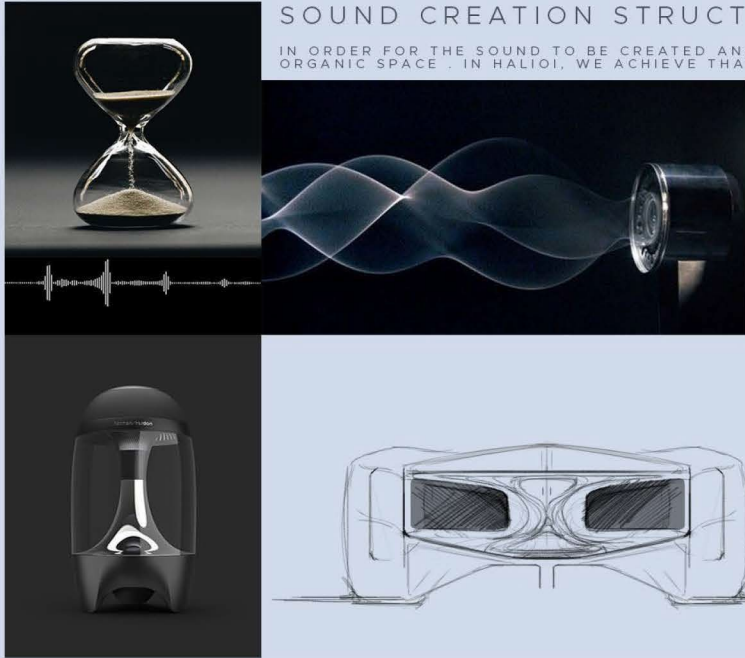

SOUND HALL

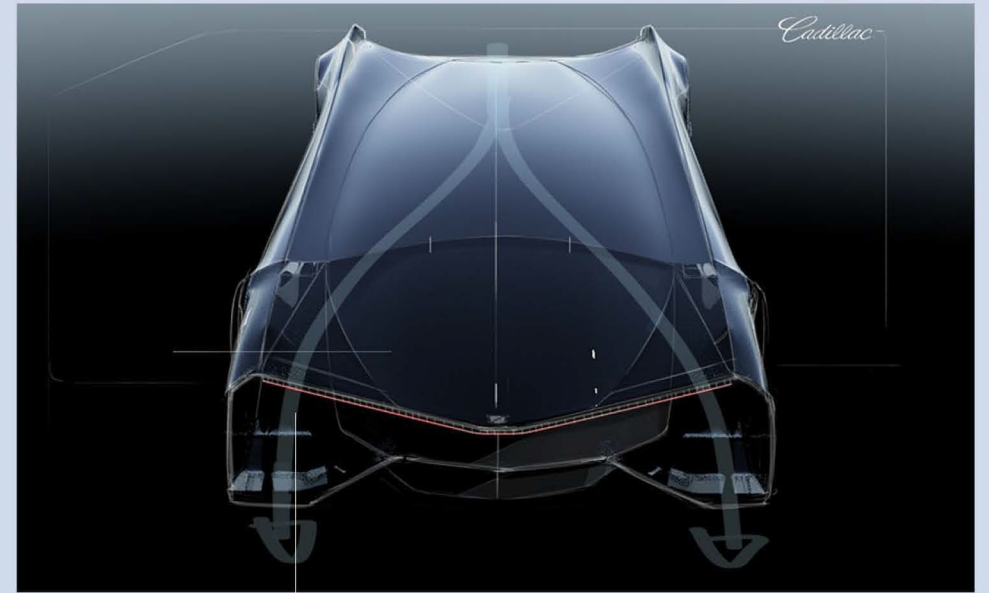
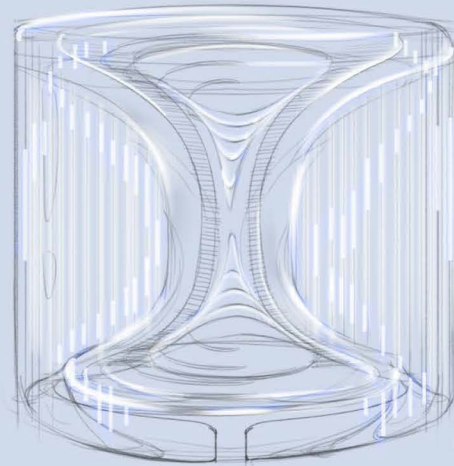

JET PROPULSION EXHAUST DEVELOP

SOUND CREATION _ACTIVATED

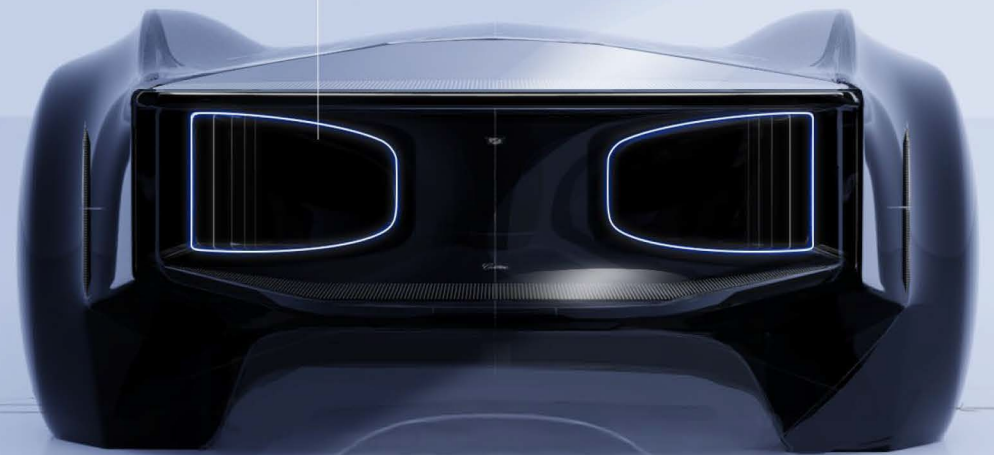

SOUND BECOMES VISUAL IN HOUR GLASS

THIS DROPPING HOURGLASS PARTICLE LIGHTS INDICATE THAT OUR CUSTOMER IS IN LUCID DREAM WORLD WHERE THEY ARE HAVING SOUND WAVE THERAPY AND TIME LEFT FOR THE THERAPY.



JET PROPULSION DECOMPRESSION EXHAUST

BIOLUMINESSCENCE

THE STARRY PARTICLES FROM THE OCEAN CIRCLE AROUND FROM THE FUSELAGE TO THE REAR JET PROPULSION ROOM TO SHOW OUR CUSTOMER IS IN SOUND THERAPY MODE. NO ELECTRICITY NEEDED FOR THE LIGHT IN THIS VEHICLE

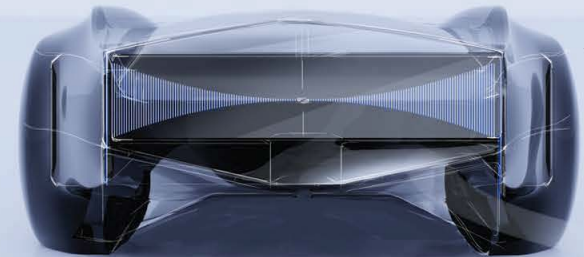
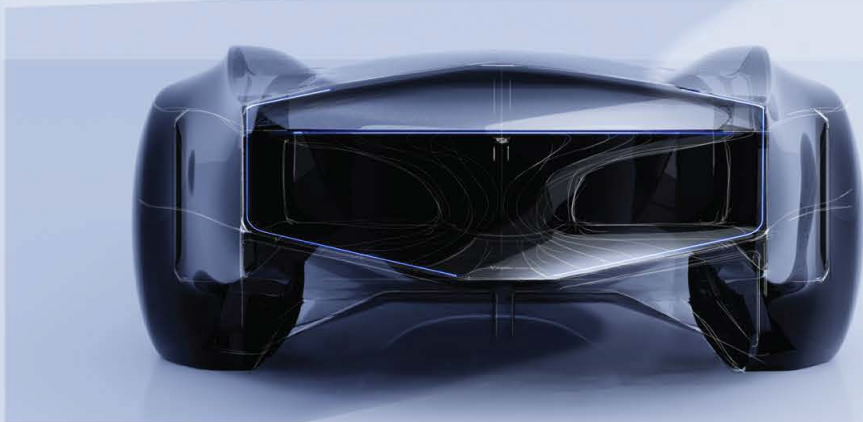
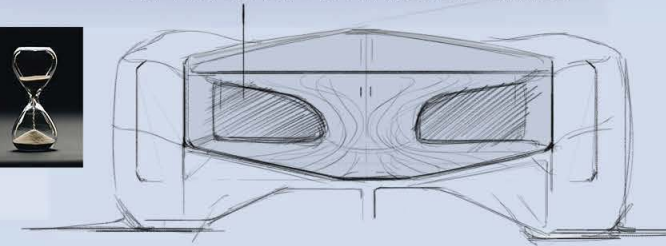



Cadillac

BEYOND IMAGINATION

HALO I



CADILLAC
HALIO

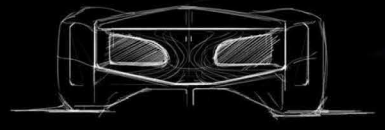

CADILLAC

HALO

LIFE, BEYOND IMAGINATION



CADILLAC

HALO

LIFE, BEYOND IMAGINATION



CADILLAC

HALLOI

LIFE, BEYOND IMAGINATION

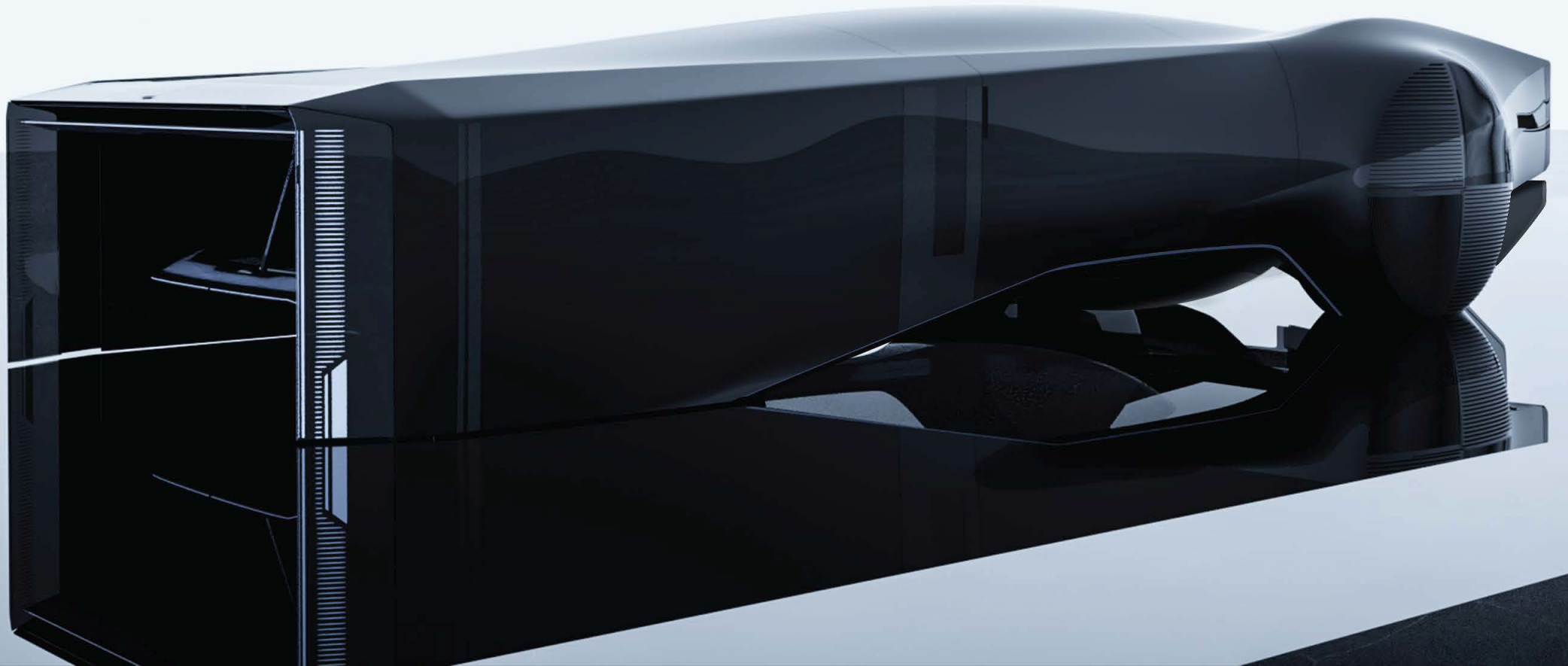

CADILLAC

HALIOI

LIFE, BEYOND IMAGINATION



CADILLAC

HALIOI

LIFE. BEYOND IMAGINATION





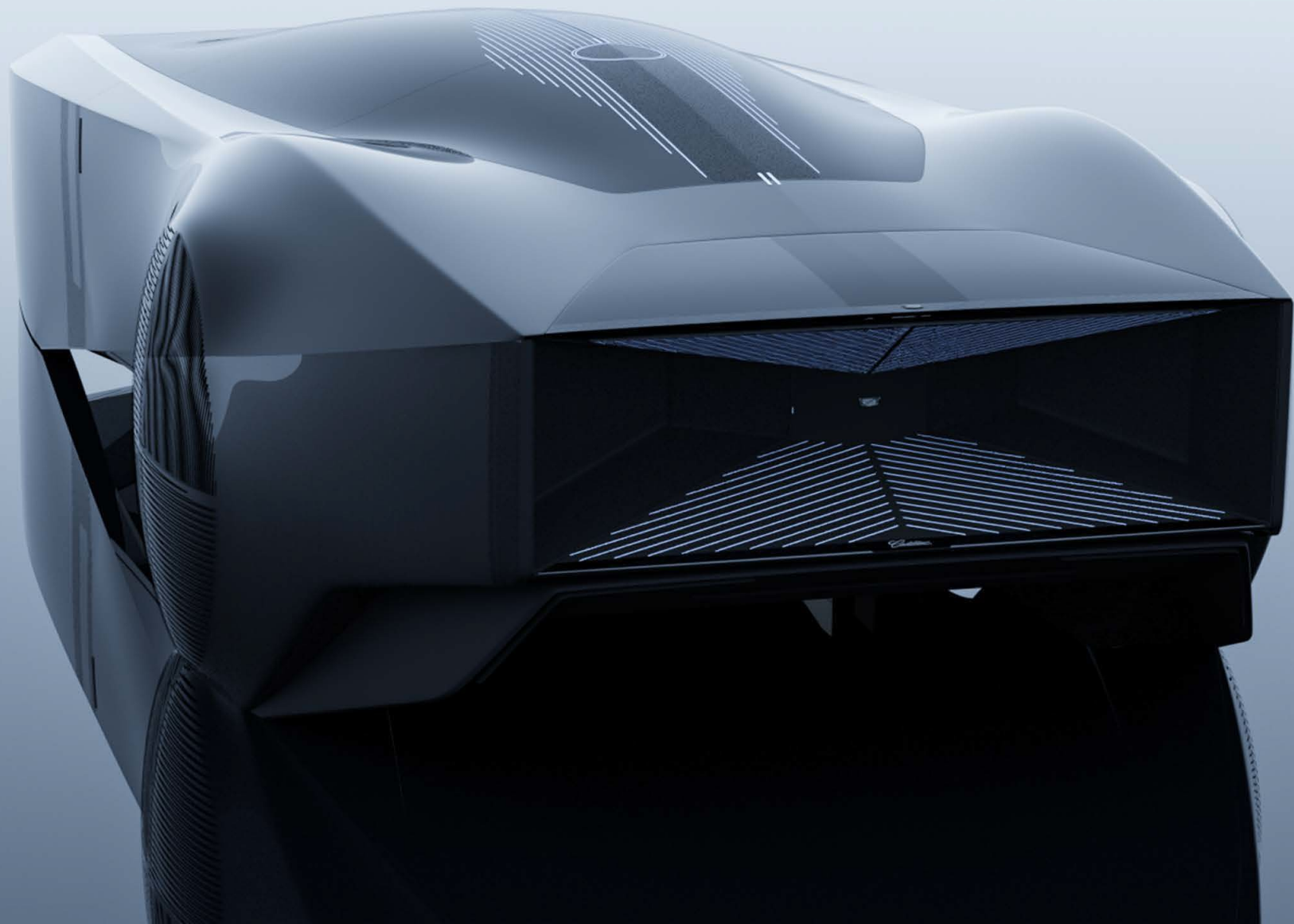

CADILLAC
FLAGSHIP; HALIOI



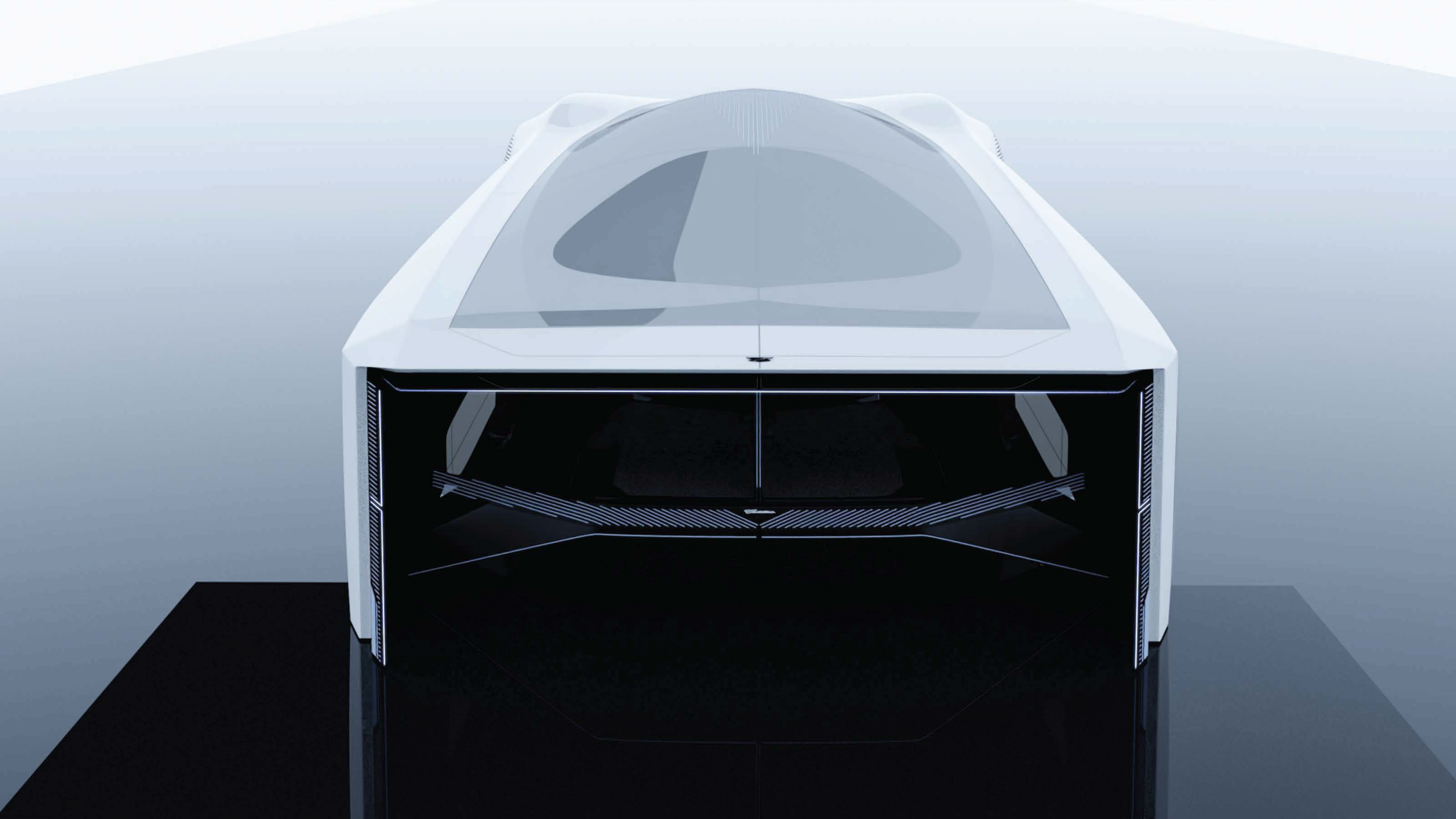

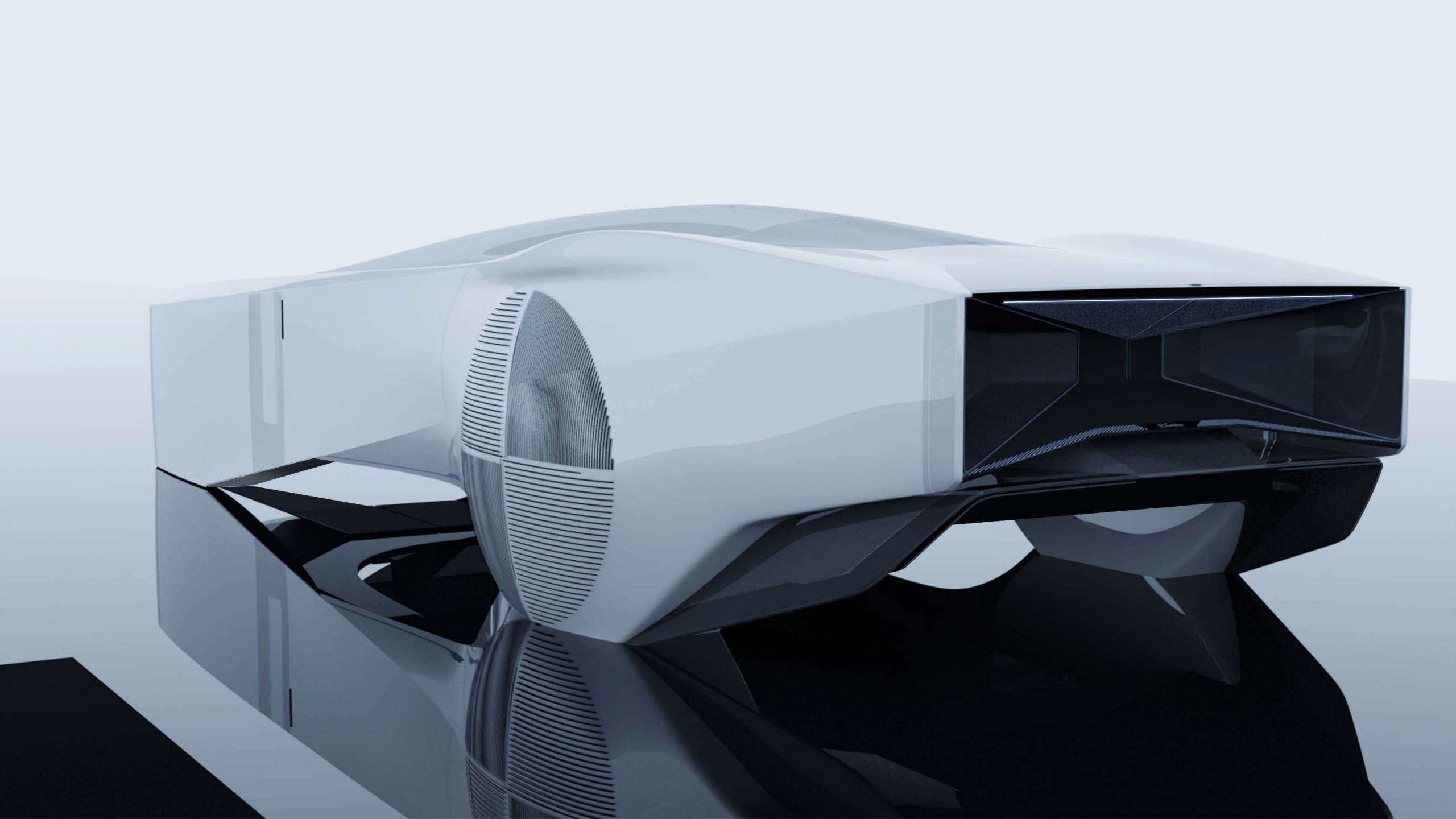

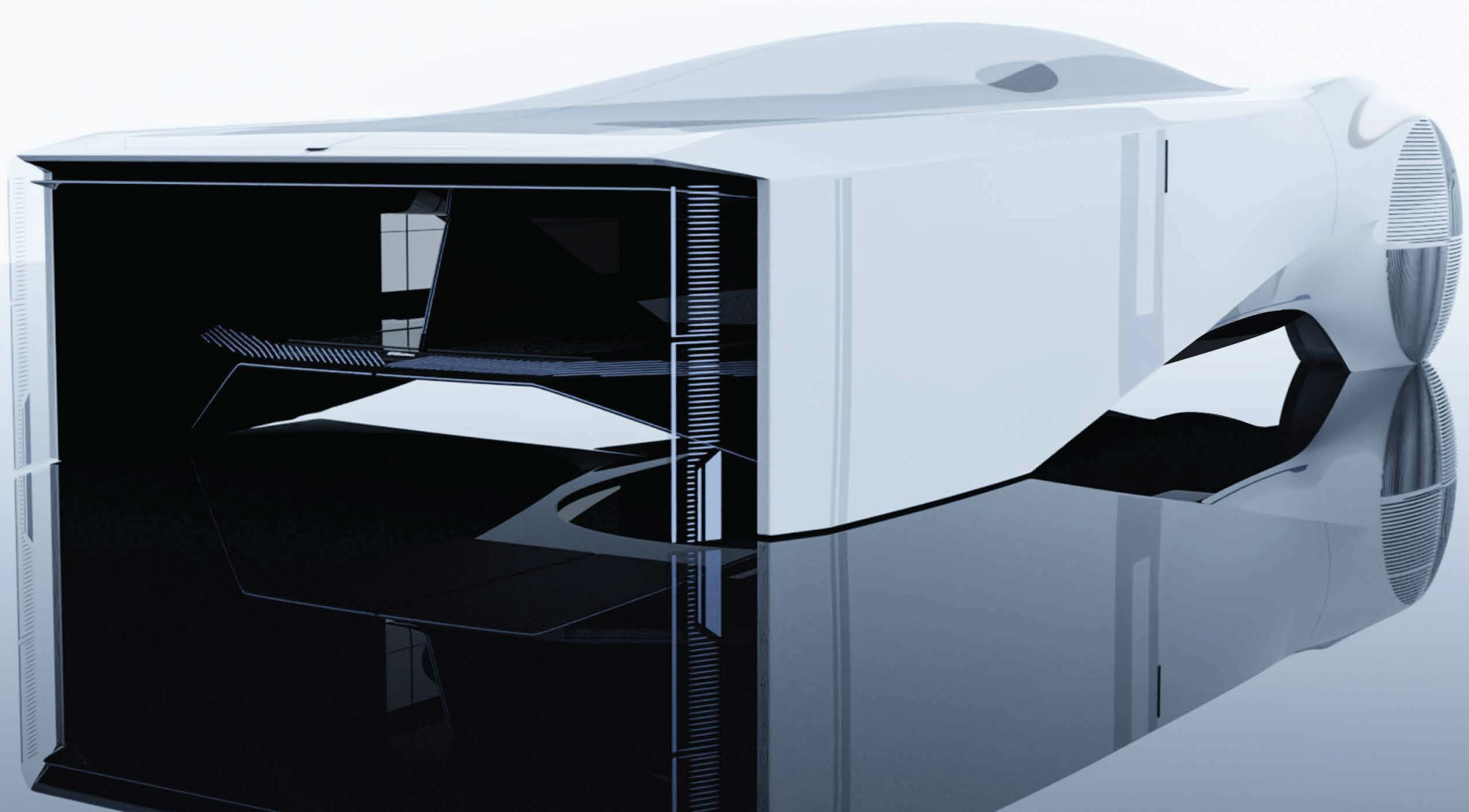





CADILLAC
HALLOI
LIFE, INTO THE NEW WORLD



CROWD AND STRESSFUL

NOWADAYS, CITIES ARE BECOMING MORE
STRESSFUL, COMPLICATED AND CROWDED
PLACES THAT LEADS PEOPLE TO THINK

CITY

"I WANT TO GET OUT OF HERE"



FREE AND COLORFUL

EVERYTHING AROUND YOU CHANGES AS
TIME GOES BY BUT NATURE. THEREFORE,
SOMETIMES WE ARE JUST MEANT TO BE
BACK TO THE NATURE.

“OPEN YOUR OWN JOURNEY”

NATURE





OPEN
YOUR JOURNEY

RIVIAN JARDIN.





STUDIO, OSLO
MODERN
MOBILITY HUB
TECHNOLOGY

JOURNEY MAP 1620 KM / 22H

WHETHER YOU ARE IN THE MODERN CITY OR EVEN IN THE HARSH NATURE, THIS RIVIAN HALO VEHICLE WILL ALWAYS BE THERE FOR YOU TO COMPLETE THE JOURNEY. IN THE MODERN CITY LIKE OSLO, THIS VEHICLE WILL PROVIDE FULL OF USABILITY AND IN THE SNOWY TROMSO, THIS WILL PROVIDE FULL OF ADVENTUROUS EMOTION WITH SAFETY.



TROMSO

69° 38' 57.1488" N
18° 57' 19.1664" E

OSLO

59° 54' 41.3676" N
10° 45' 28.5588" E



NATURE, TROMSO
SNOWY
ADVENTUROUS
OUTDOOR



RIVIAN

FROM
CITY



§

YOUR ROOM CAN BE AT
ANYWHERE

WORK — REST — DRIVE
||



RIVAIN

TO
NATURE

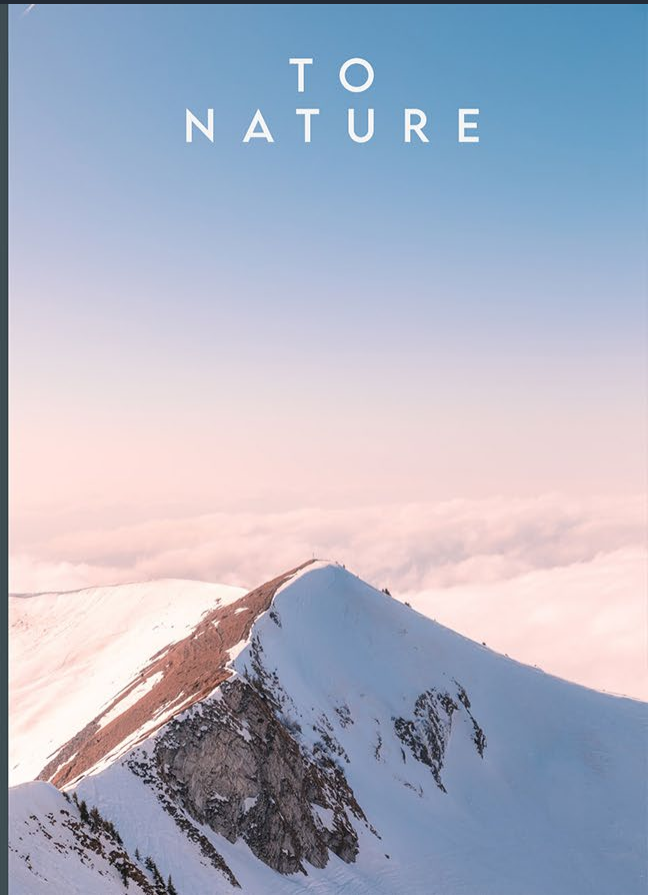

JARDIN_
OPEN YOUR OWN JOURNEY



TRANSPARENT CHAMBER_

TO ENJOY NATURAL GARDEN CALLED "EARTH"

EXO SKELETON STRUCTURE THAT
CONNECTS FROM THE FRONT TO THE REAR
IN ORDER TO SUPPORT THE CHAMBER



KEY SKETCH

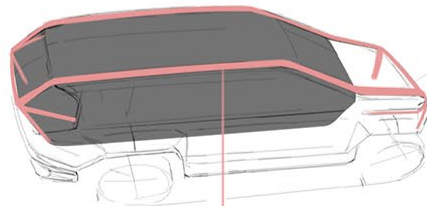
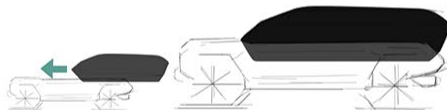
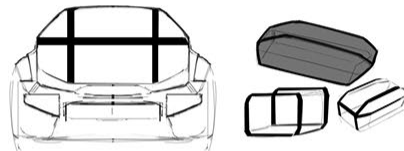
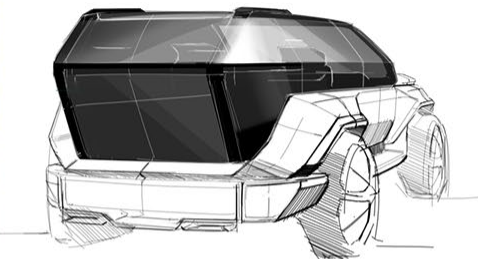

EXO SKELETON SUPPORTING THE CHAMBER WRAPS AROUND
THE VEHICLE FROM THE FRONT TO THE REAR AND
IT BECOMES LIGHT GRAPHIC.

RIVAIN

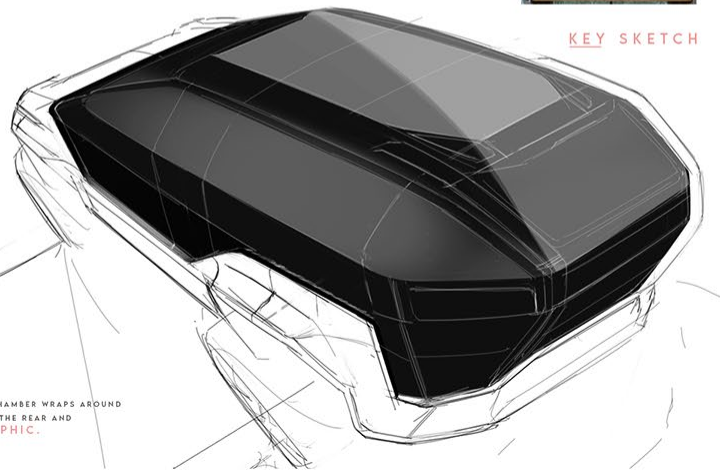

JARDIN_
OPEN YOUR OWN JOURNEY

PROTECTIVE GRAPHIC

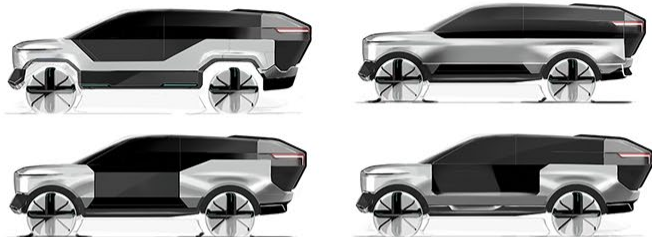

KEY SKETCH

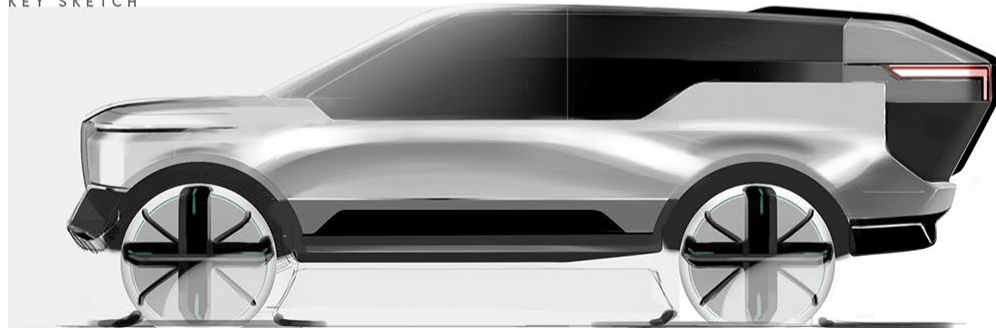

RIVAIN

PROTECTIVE BODY_

TO PROTECT AND SECURE THE MAIN BODY

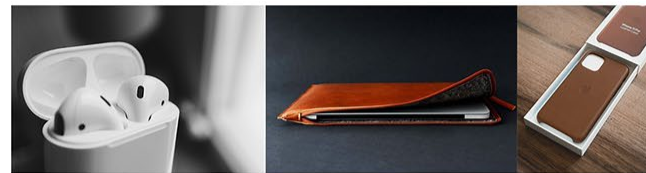

JUST LIKE THESE **CASES** PROTECT THEIR DEVICES, RIVIAN BODY
PROTECT ITS CHAMBER BY WRAPPING AROUND THE CHAMBER.

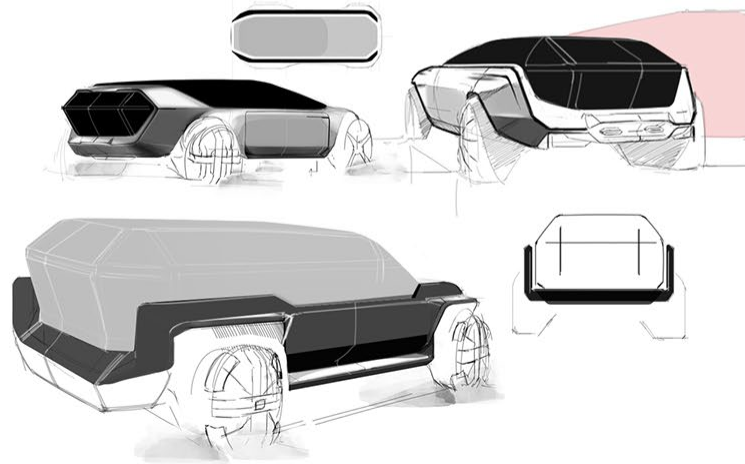

JARDIN_
OPEN YOUR OWN JOURNEY

INSPIRED BY JAPANESE TRADITIONAL ENTRANCE CALLED "TORII GATE"
MEANING A TRANSITION FROM THE MUNDANE TO THE SACRED

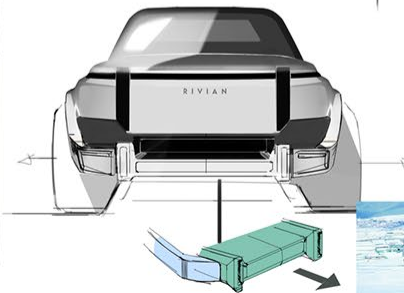

FORM FOLLOWS FUNCTION_
BUMPER BECOMES A CHAIR

RIVIAN

STRUCTURAL FACE_

TO PROVIDE STURDY AND STABLE EMOTION

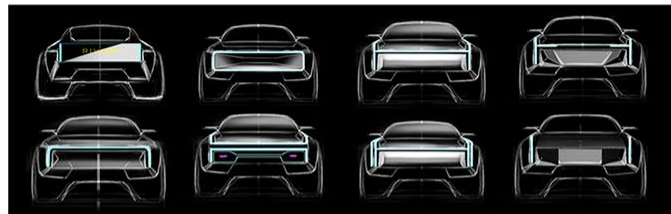

LIGHT GRAPHIC STUDY

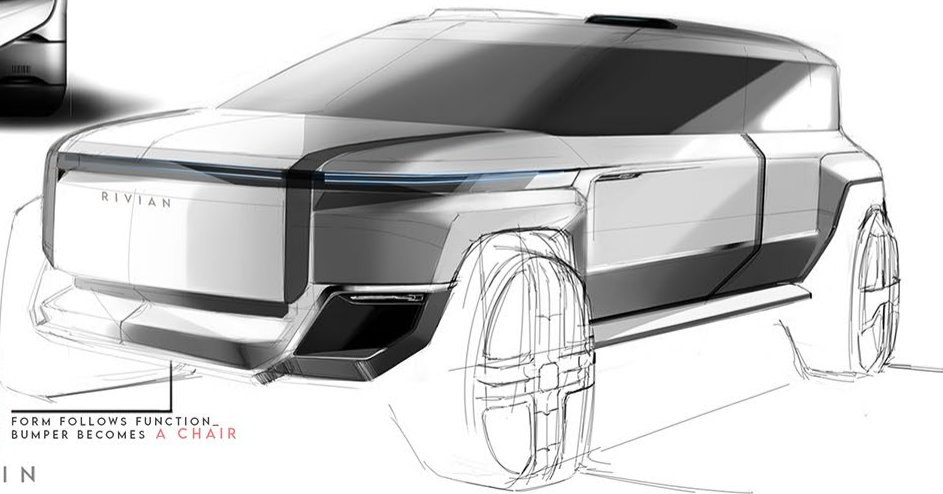

JARDIN_
OPEN YOUR OWN JOURNEY



HIGH SPACE UTILITY is provided with this vehicle thanks to the RIVIAN'S ELECTRIC PLATFORM. YOU CAN USE THIS SPACE AS A FRUNK FOR YOUR STORAGE OR UNEXPECTED SPACE FOR YOUR COFFEE TIME.

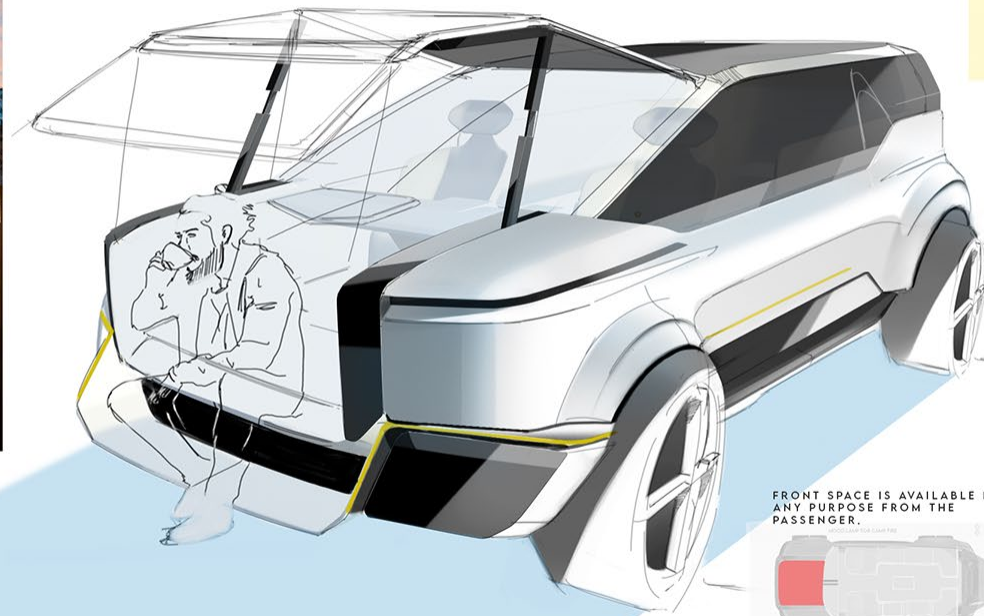

RIVAIN

UNEXPECTED FRONT_

TO PROVIDE HIGH SPACE UTILITY FOR THE JOURNEY

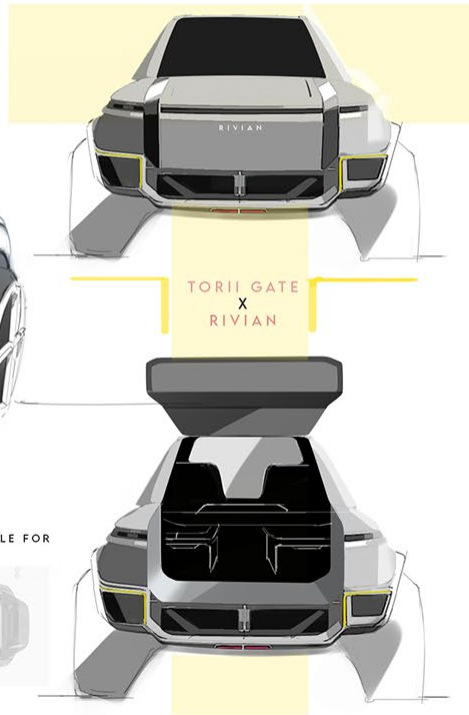

FRONT SPACE IS AVAILABLE FOR ANY PURPOSE FROM THE PASSENGER.

JARDIN_
OPEN YOUR OWN JOURNEY



REAR GRAPHIC EXPLORATION

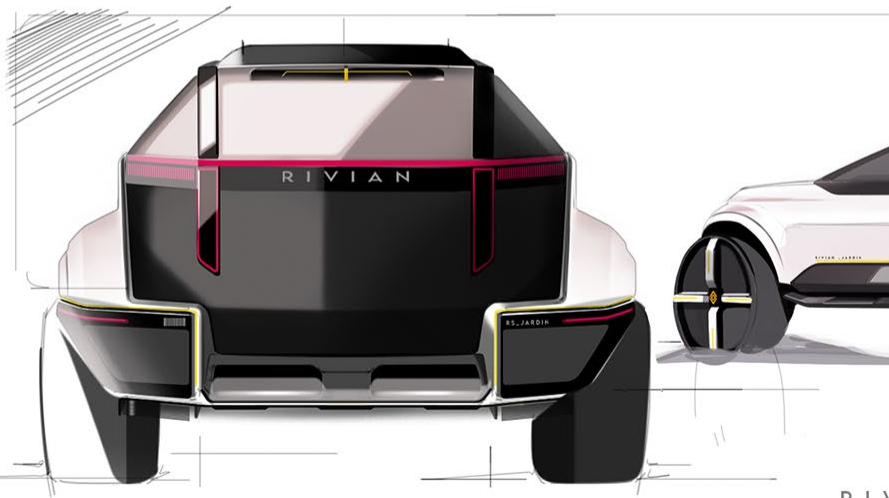

RIVAIN

STRUCTURAL REAR_

YOUR OWN ENTRANCE FOR YOUR OWN JOURNEY

TORII GATE AT THE REAR

REAR DOOR BECOMES TORII GATE FOR PASSENGERS TO ENTER OR EXIT



TORII GATE_

ENTERING THROUGH TORII GATE MEANS A TRANSITION TO WHERE I AM INHERENTLY MEANT TO BE.





FRONT_
DEVELOPMENT



REAR_
DEVELOPMENT



URBAN LIFE

ARCHITECTURAL_MODERN

ARCHITECTURALLY DESIGNED INSPIRED BY A NUMBER OF ARCHITECTURAL PATTERN WE CAN FIND IN CITIES. ALSO, INSPIRED BY A CLOCK DESIGN WITH COVERED WITH FOUR SURFACES WHICH ENHANCES AERODYNAMIC EFFICIENCY.



SNOW TENG_ ELECTRIC NANO GENERATOR

WHEN SNOW TOUCHES THE SILICONE MATERIAL ON THE TIRE(OUTER PART OF SNOW TENG), IT ABSORBS - ELECTRON FROM SNOW AND DELIVER IT TO THE SNOW TENG WHICH IS FULL OF + ELECTRON. AND THIS PHENOMENON CHEMICALLY GENERATE ELECTRICITY IN NATURAL STATE

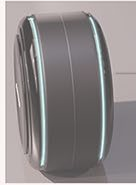

CHARGING INDICATOR

OUTDOOR LIFE

STURDY_HEXAGON

HEXAGON IS THE MOST STURDY AND SECURE SHAPE THAT NATURE HAS PRESENTED TO US. SO DOES THE DESIGN FROM RIVIAN TO YOU.

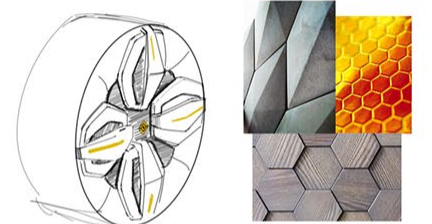
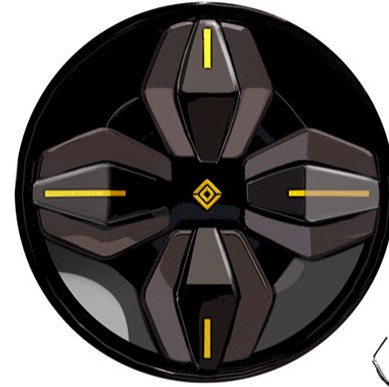

VEHICLE TYPE & PACKAGE



USABILITY
CAPABILITY

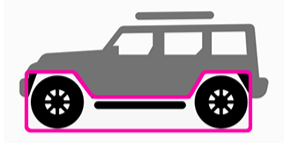

ADVENTURE
ON/ OFF ROAD

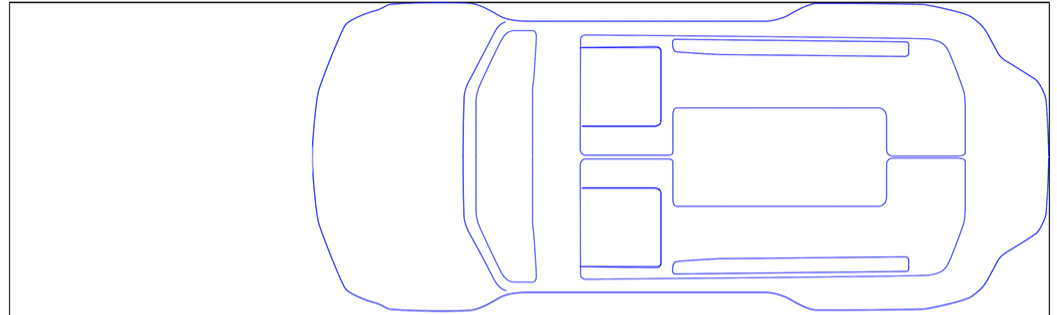
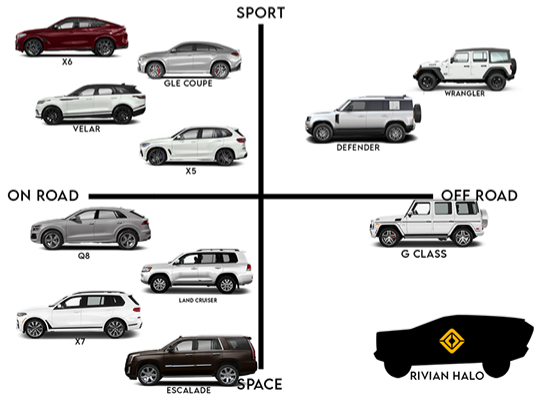

PACKAGE IN COMPARISON WITH
BMW X5 (2019)

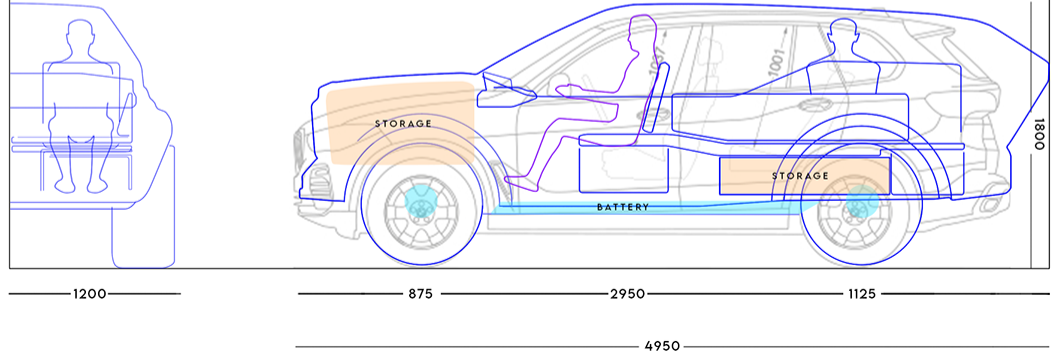



FRONT
QUARTER

SIDE VIEW

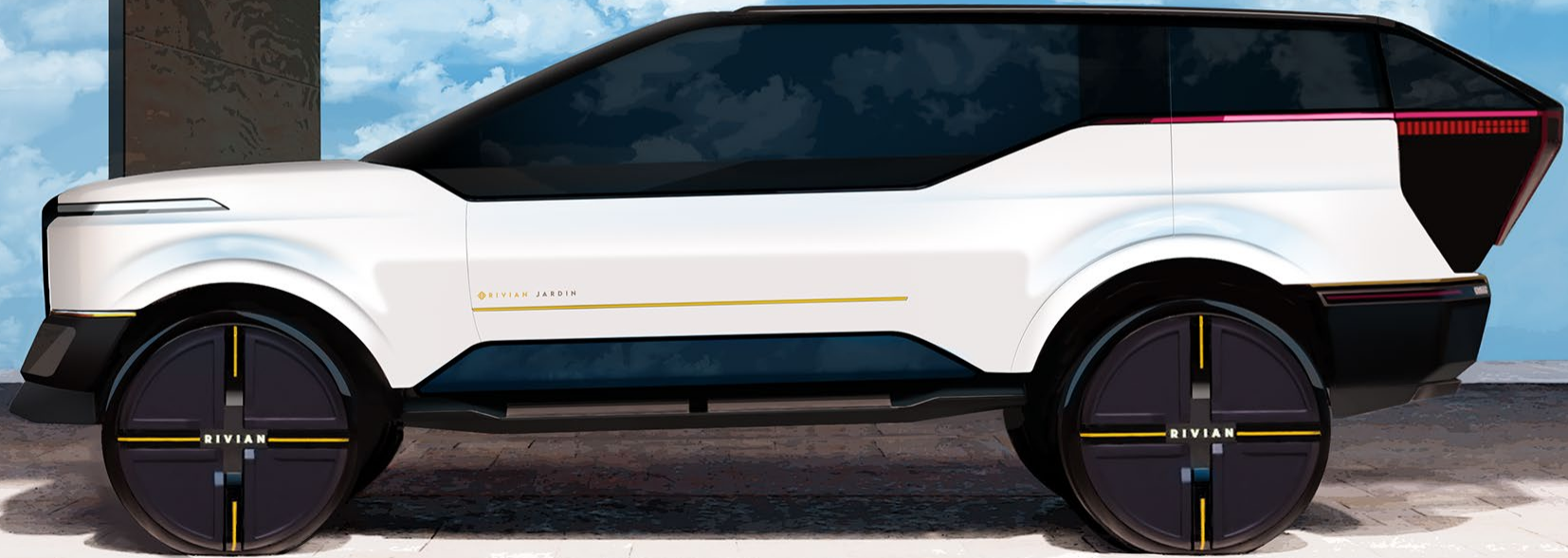

RIVIAN JARDIN

RIVIAN

RIVIAN

REAR
QUARTER



RIVIAN

RIVIAN

RIVIAN

INTERIOR _



DRIVE _



REST _



WORK _

INITIAL SKETCH_

OVERALL STRUCTURE

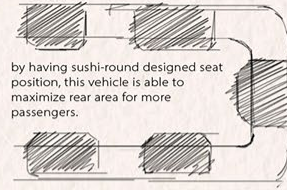

by having sushi-round designed seat position, this vehicle is able to maximize rear area for more passengers.

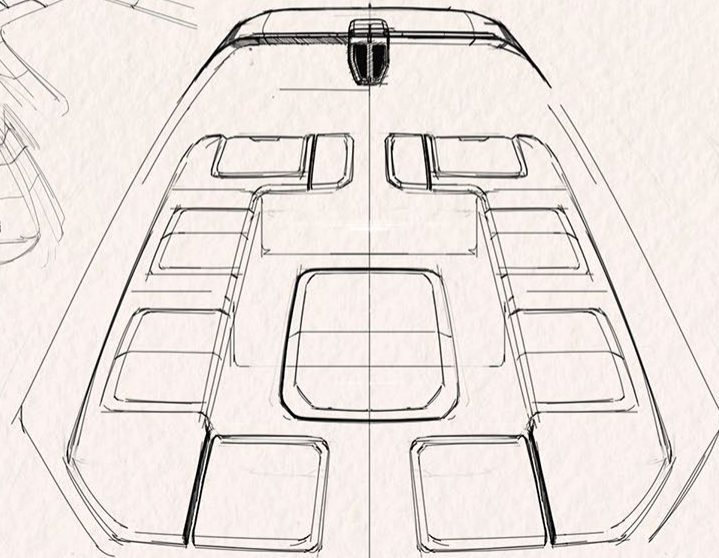
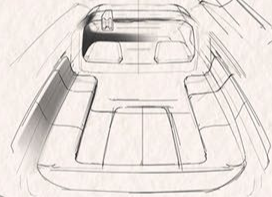
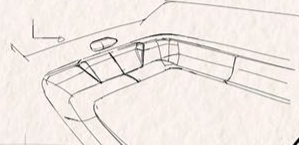
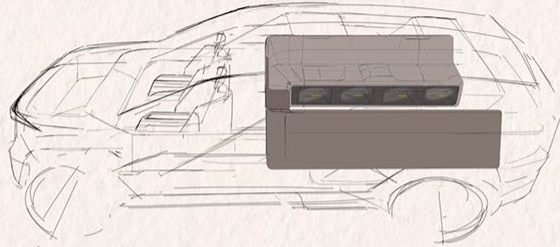
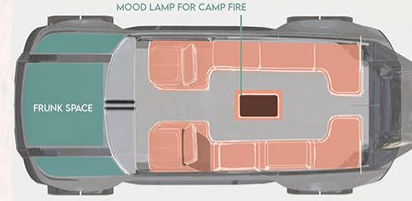

INITIAL SKETCH _ DASHBOARD

:IN THE DAYS OF AUTONOMOUS, ELECTRIC AND VR-DRIVEN ERA, THE MAJORITY OF SPACE COULD HAVE FREEDOM TO BE TRANSFORMED.

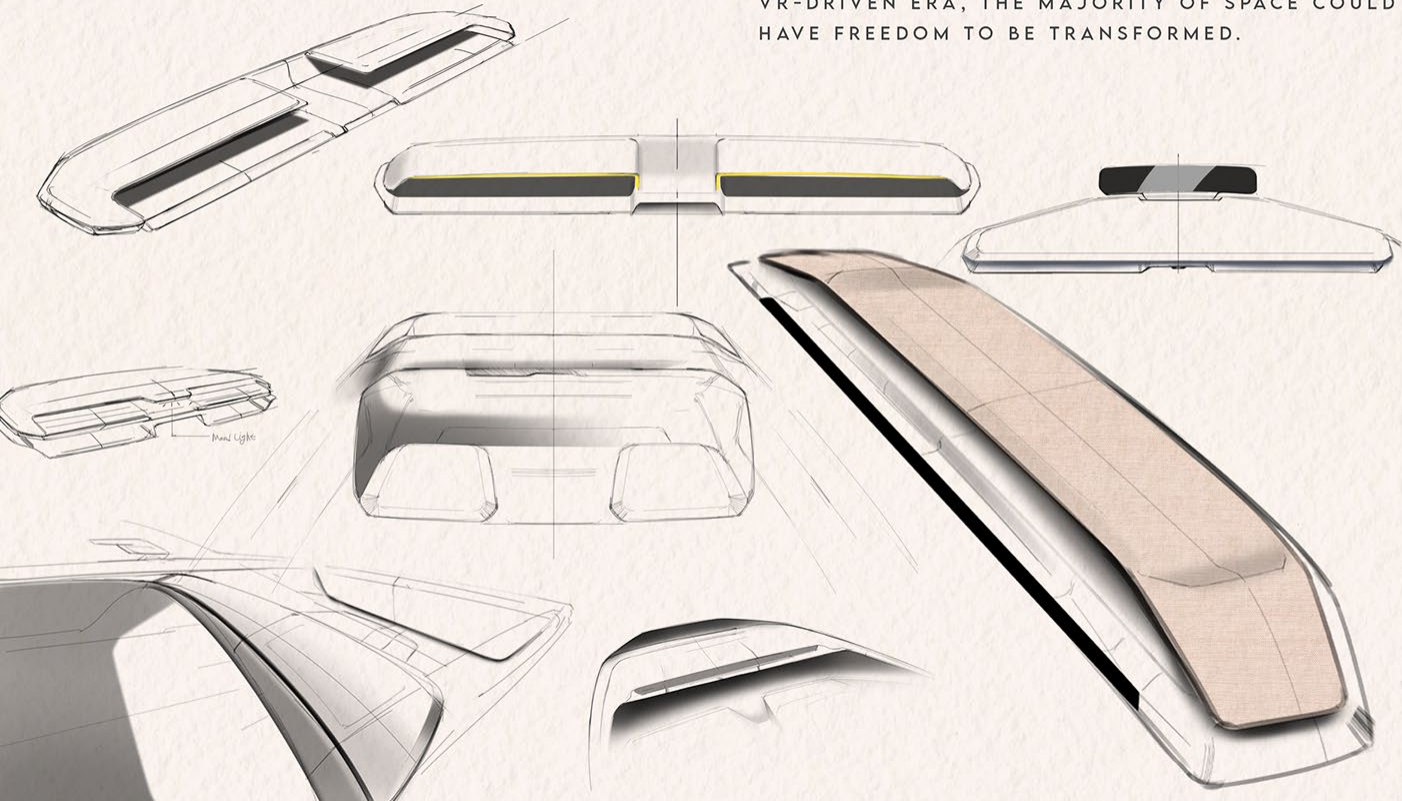

DRIVE AREA



WORK AREA



FRONT_



DEVELOPMENT_DASHBOARD & STEERING WHEEL



R E A R _

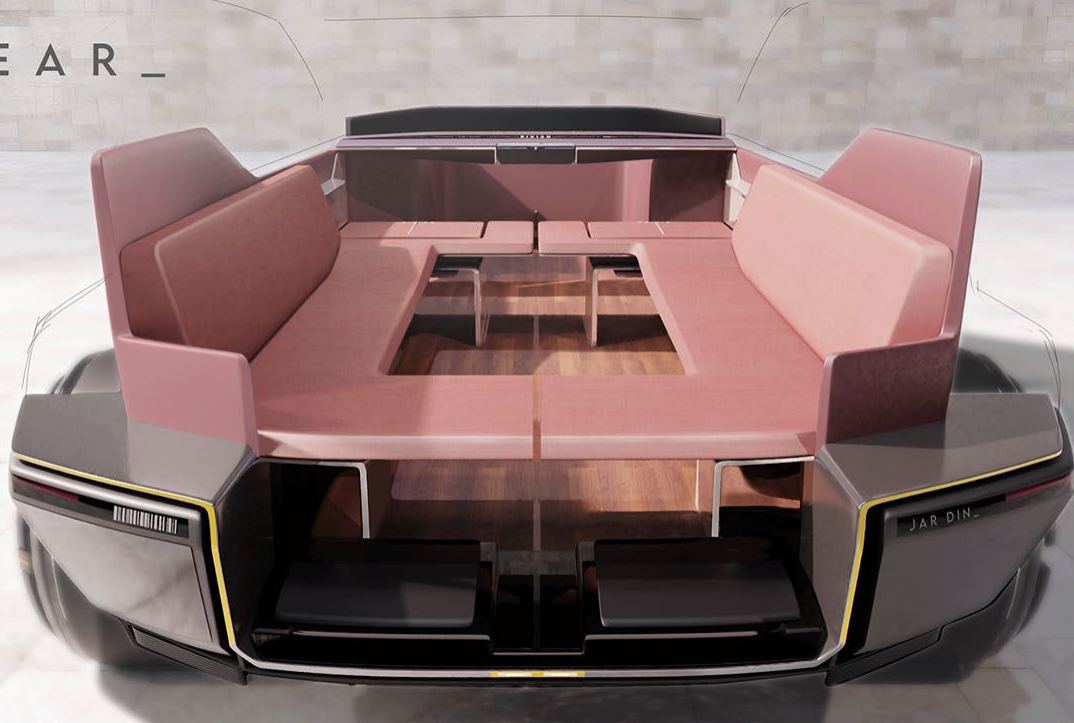

DEVELOPMENT_
OVERALL STRUCTURE

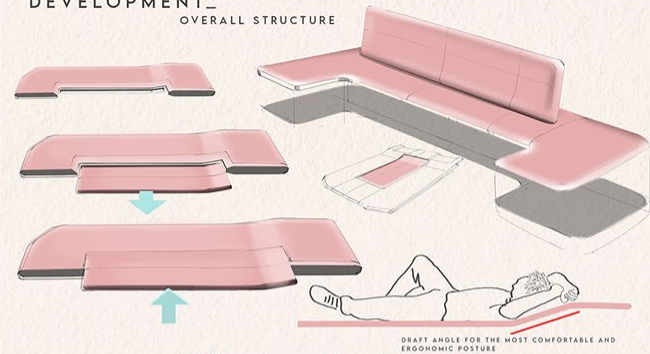

T O P _



DEVELOPMENT_
OVERALL STRUCTURE



ADDITIONAL STORAGE BENEATH THE SEAT



FRONT QUARTER

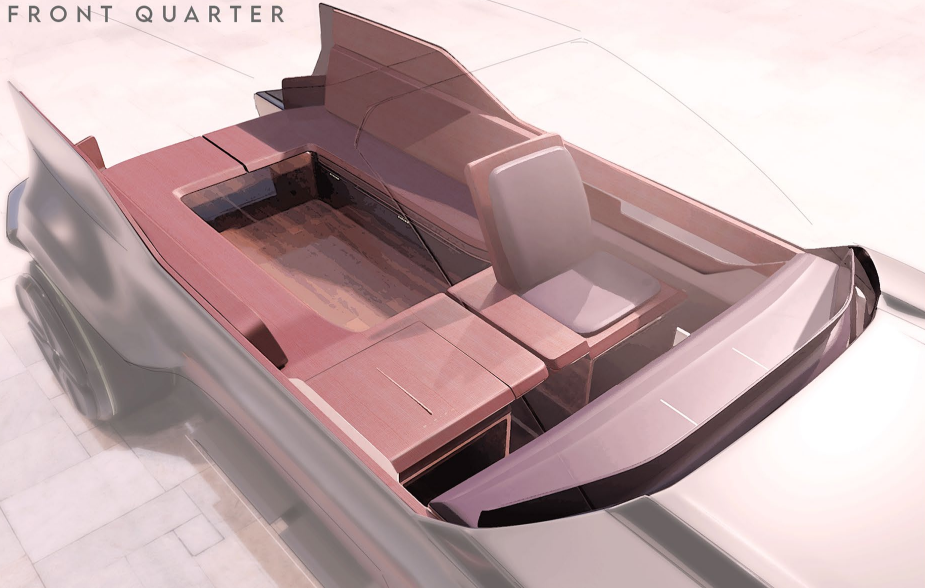

REAR QUARTER

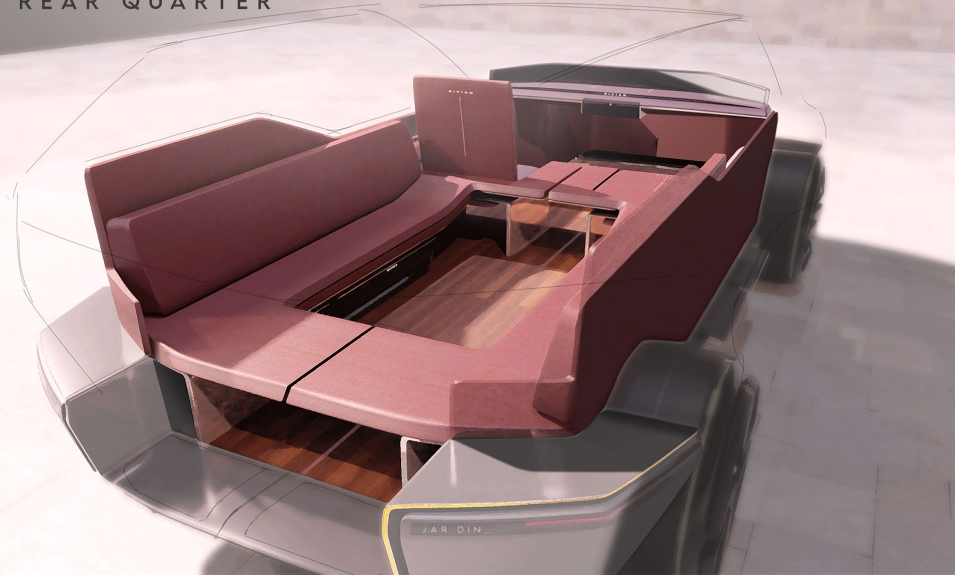





RIVIAN



RIVIAN

RIVIAN JARDIN

RIVIAN

RIVIAN





UTILITY PRODUCT

IT IS MORE THAN JUST A VEHICLE.

MOOD LIGHT

IF LOCATED INSIDE, IT BECOMES A MOOD LAMP FOR ROOM

IF COMES OUT, BECOMES A MOOD LAMP FOR CAMPING, TENT

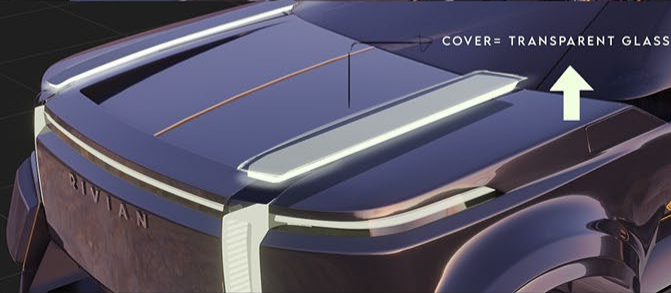
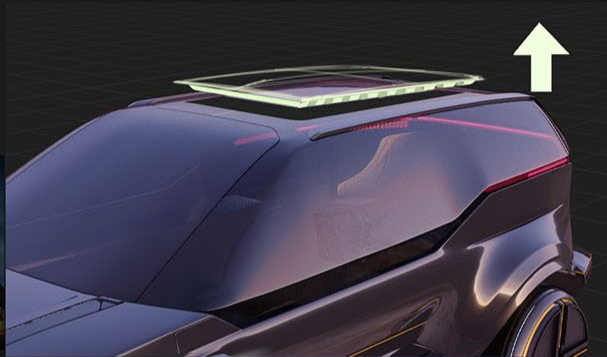

COVER= TRANSPARENT GLASS

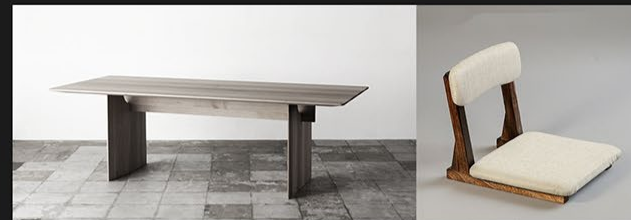

REAR



SIDE



FRONT



EACH BUMPER ON THE FRONT, REAR AND SIDE COMES OUT AND BECOMES A PORTABLE BENCH FOR THE MAXIMUM UTILITY

FUNZIONAL BUMPER

SEAT





RIVIAN



RIVIAN

RIVIAN



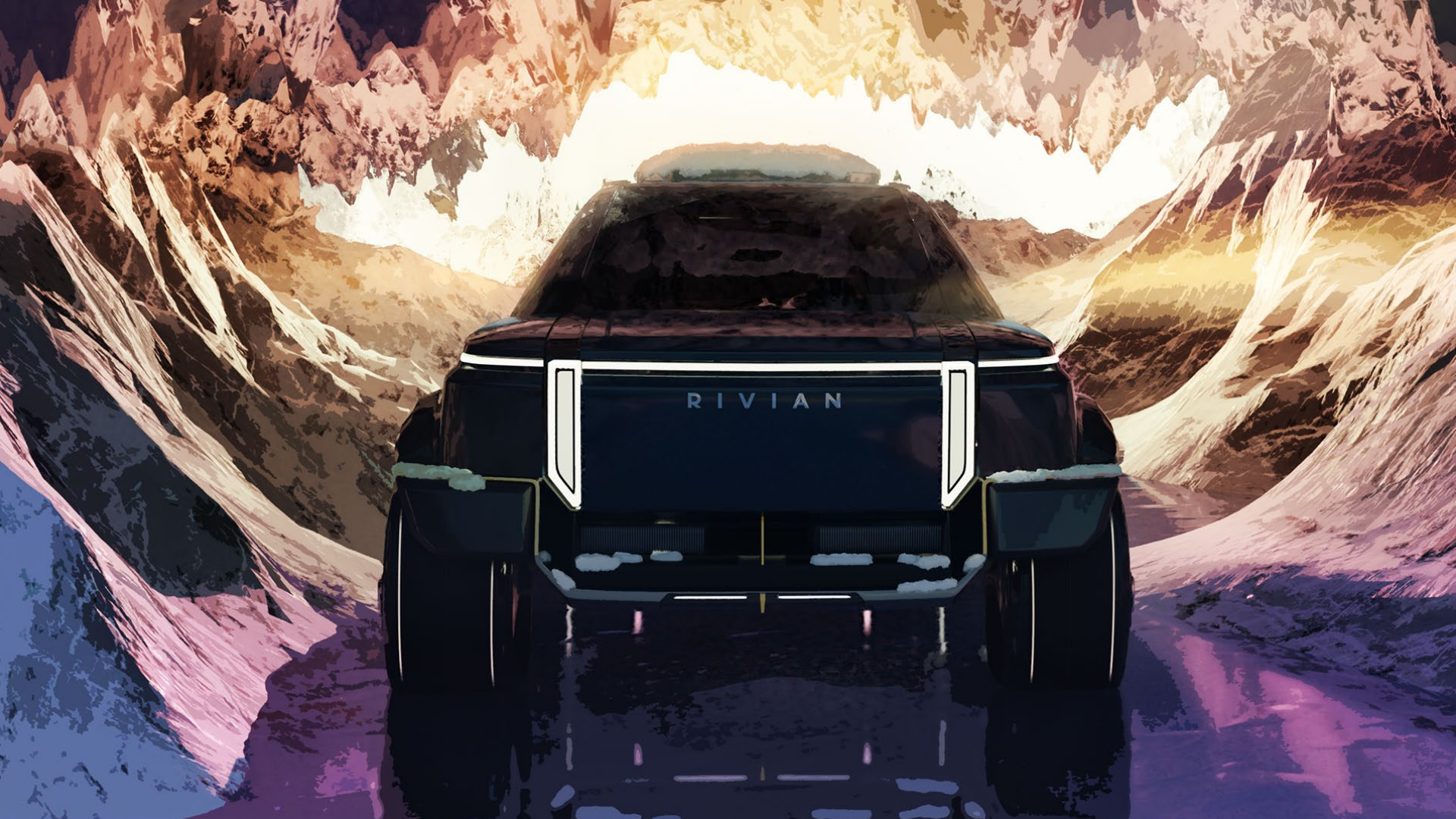

RIVIAN











AMG

DRIVING PERFORMANCE



ELECTRIC HYPER CAR FOR EVERY AUTOMAKER

HYPER CAR BRINGS PRICELESS VALUE TO BRAND BECAUSE IT REPRESENTS BRAND'S TECHNOLOGY. AND DESIGN LEVEL, WHICH LEADS TO A SUCCESSFUL MARKETING STRATEGY AND GREAT PROFIT WITH THE IMAGE. AND IN THE ERA OF ELECTRIC VEHICLE, THERE IS CHANCE FOR EVERY AUTOMAKER BECAUSE EVERYONE STANDS AT THE STARTING LINE TOGETHER. EVERYONE HAS TO BUILD NEW PLATFORM AND COMPONENTS JUST FOR ELECTRIC VEHICLE.

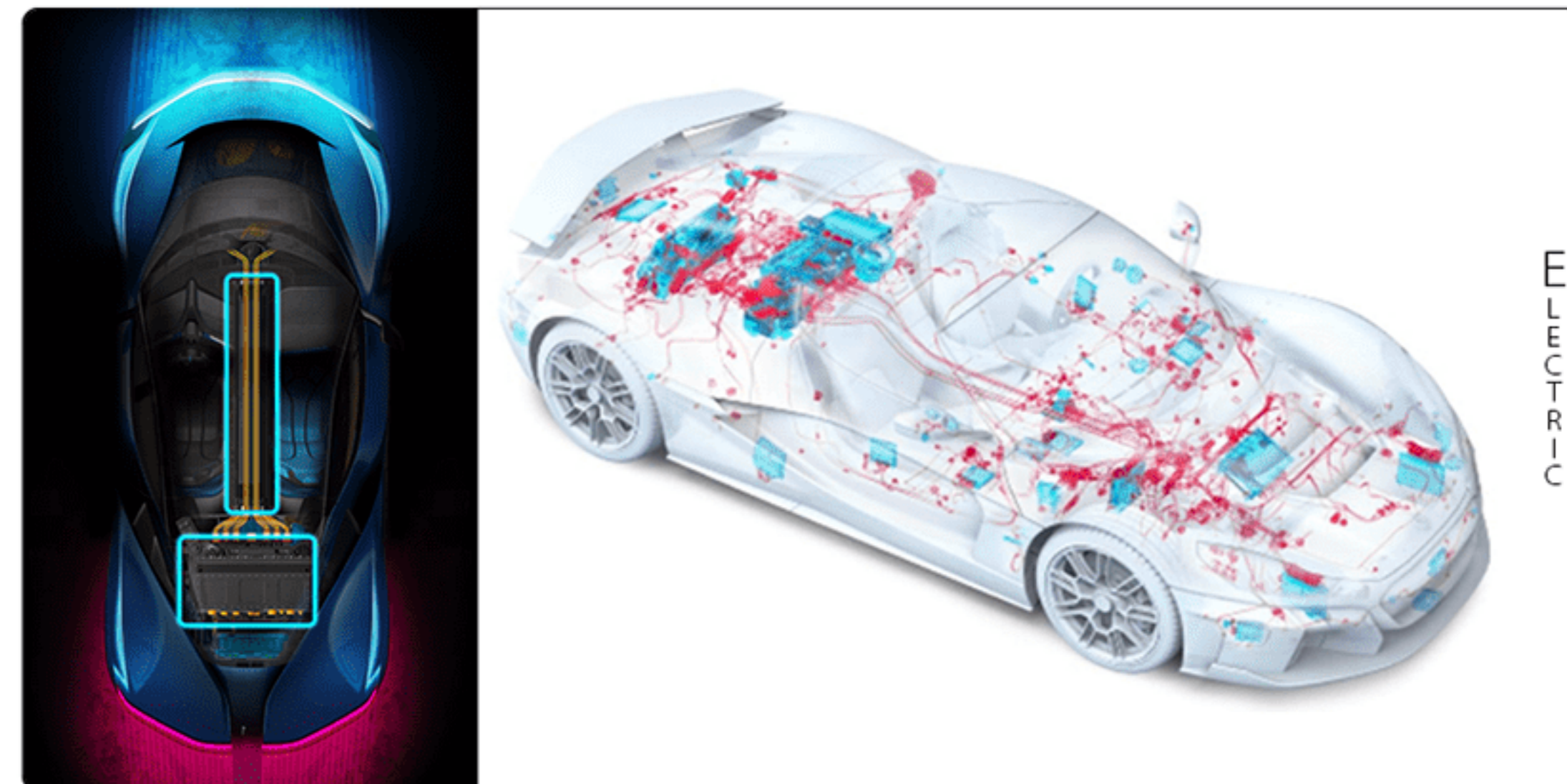



ULTIMATE LUXURY



PREMIUM



PERFORMANCE LUXURY



LINE UP

COMPETITION

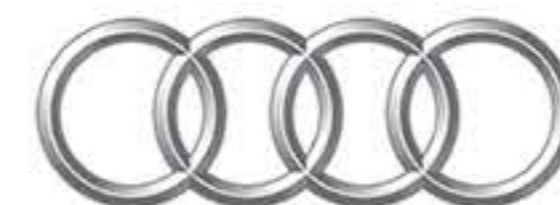



SHOOTING BRAKE

DAILY CAPABILITY

SPORTY EMOTION

SLEEK SILHOUETTE/ ROOF LINE

MORE STORAGE VOLUME THAN COUPÉ

HYPER VEHICLE

EXTREME CAPABILITY

SPORTY EMOTION

AERO EFFICIENT - ROOF

LESS STORAGE VOLUME THAN COUPÉ



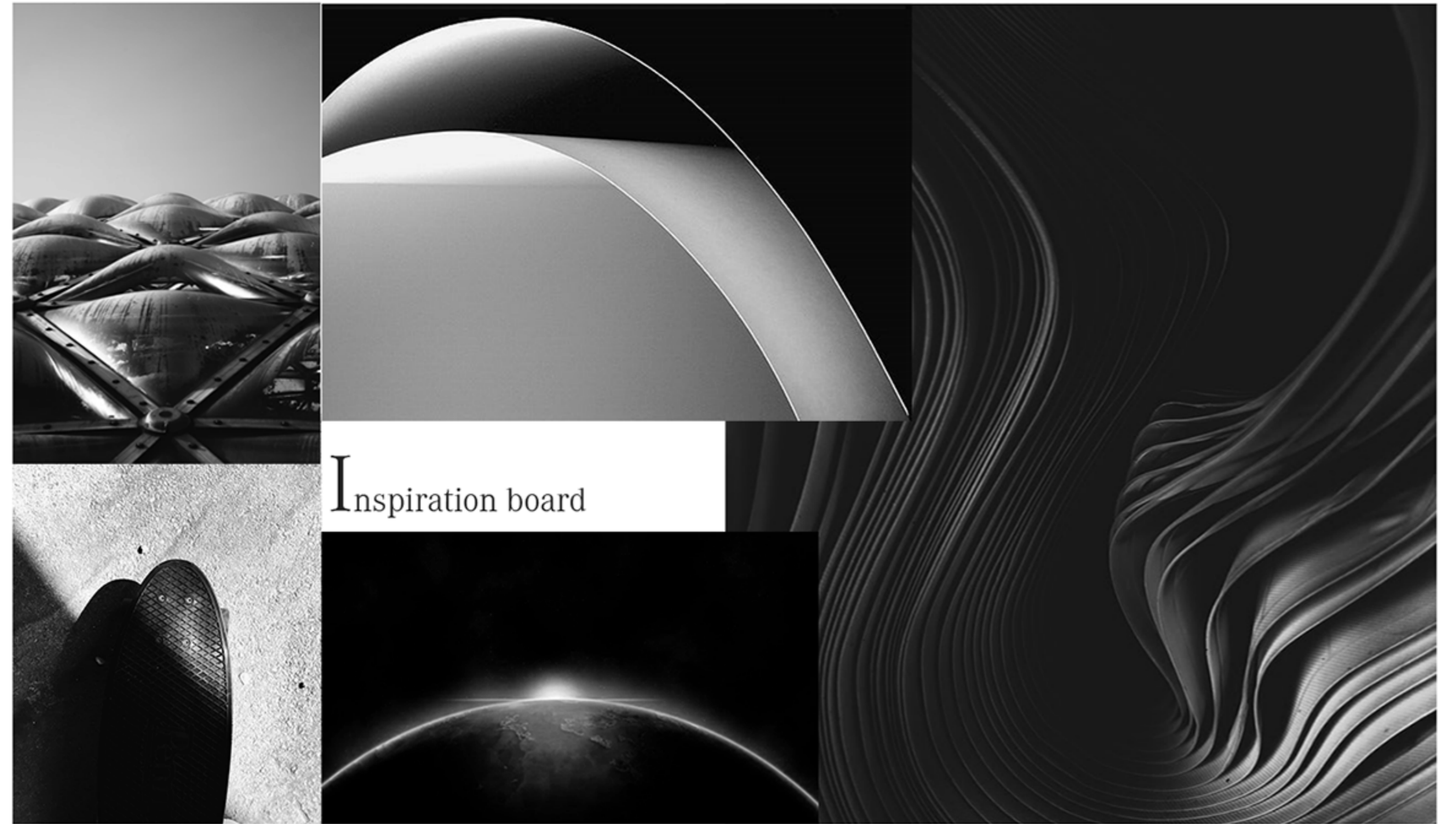

PROPORTION EXPLORATION

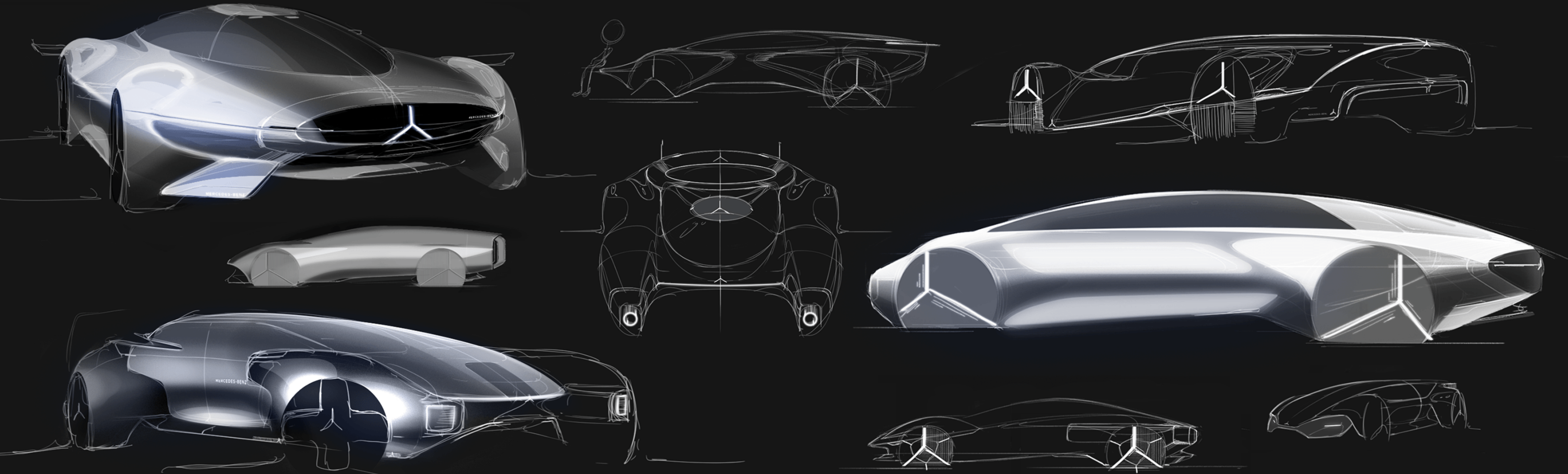

PROPORTION EXPLORATION

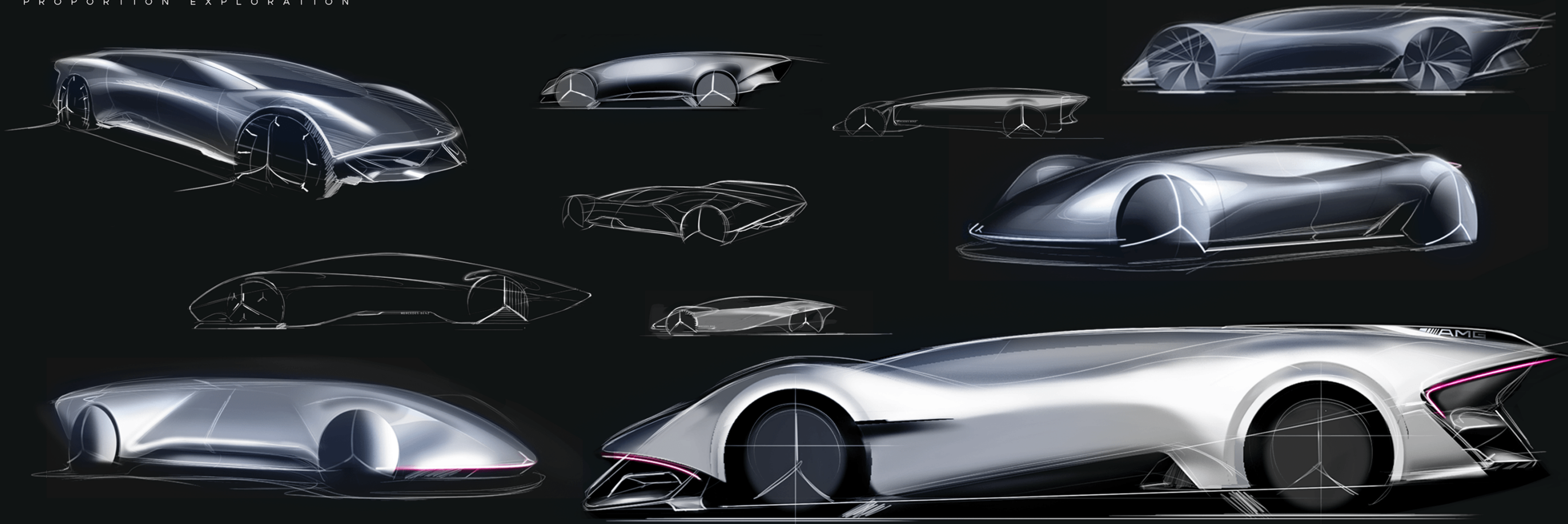

LIGHT FOLLOWS GRILLE(FORM)

IN THE ERA OF ELECTRIC VEHICLE, GRILLE WILL HAVE MUCH LIMITED FUNCTION THAN BEFORE WHICH REQUIRE MORE MINIMAL, EFFICIENT AND DISTINTIVE FRONT DESIGN

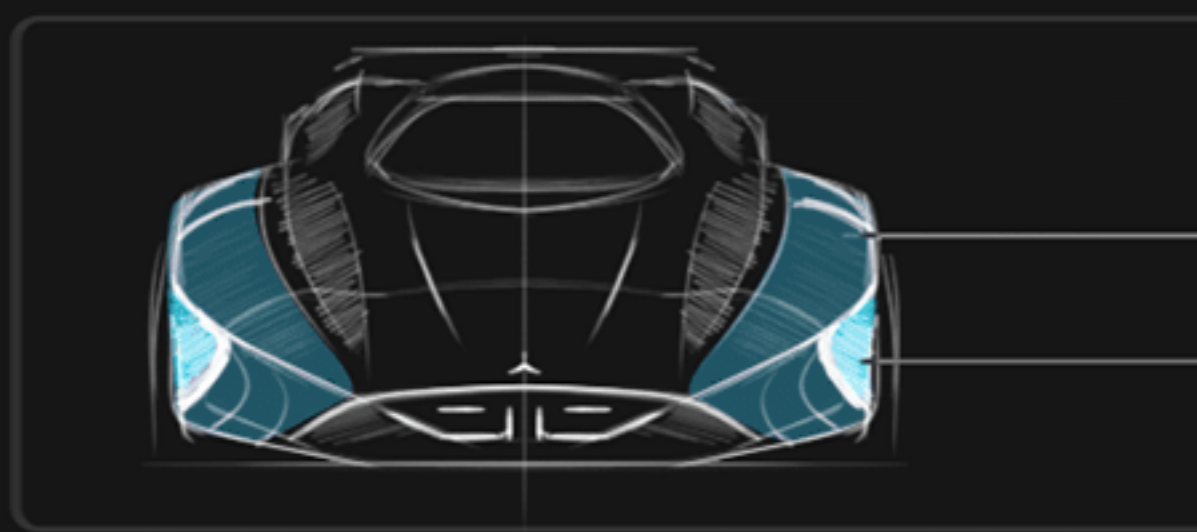

BY INTEGRATING HEADLIGHTS INTO GRILLE, THIS COULD GET EVEN WIDER FENDER POSSIBLE WHICH LEADS TO MORE OVERWHELMING PROPORTION. PLUS, THIS CAN HELP ENHANCE OVERALL AERODYNAMIC EFFICIENCY BY MINIMIZING ELEMENTS AT FRONT

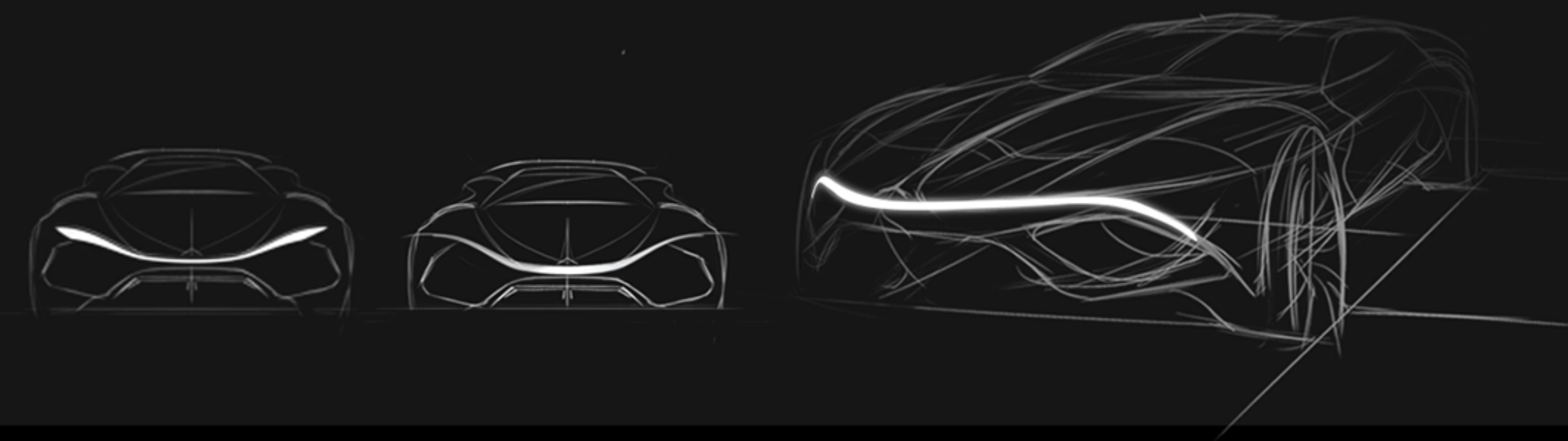
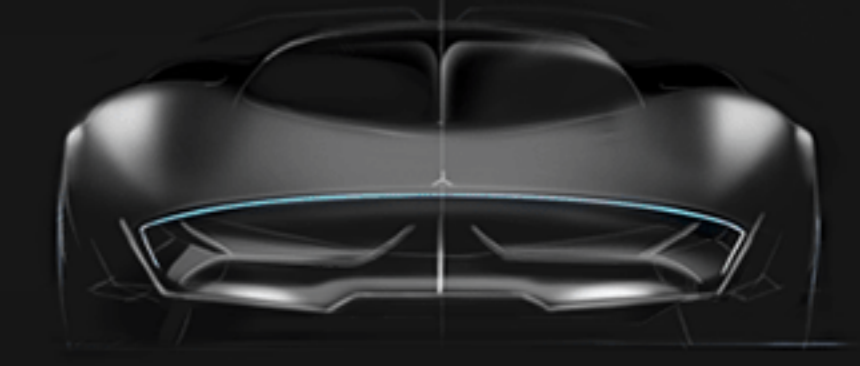
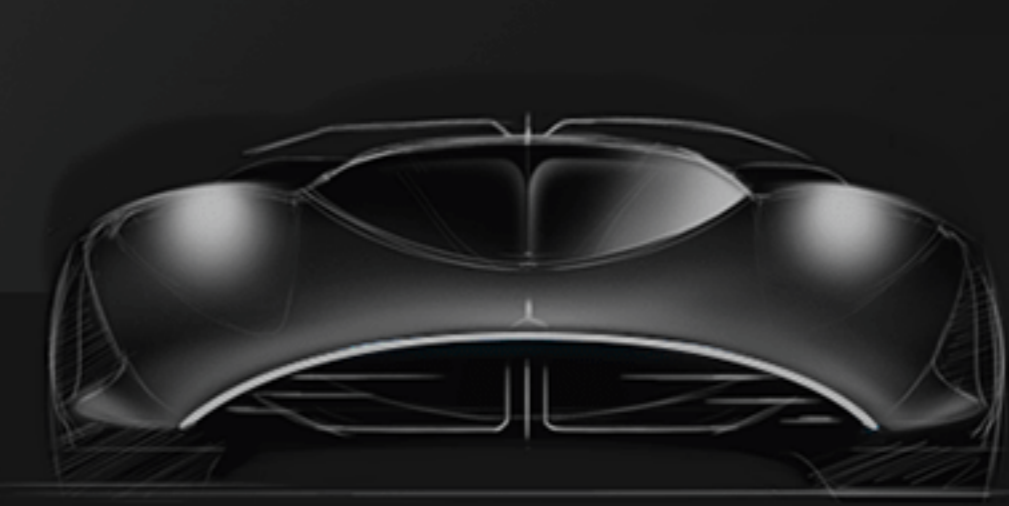
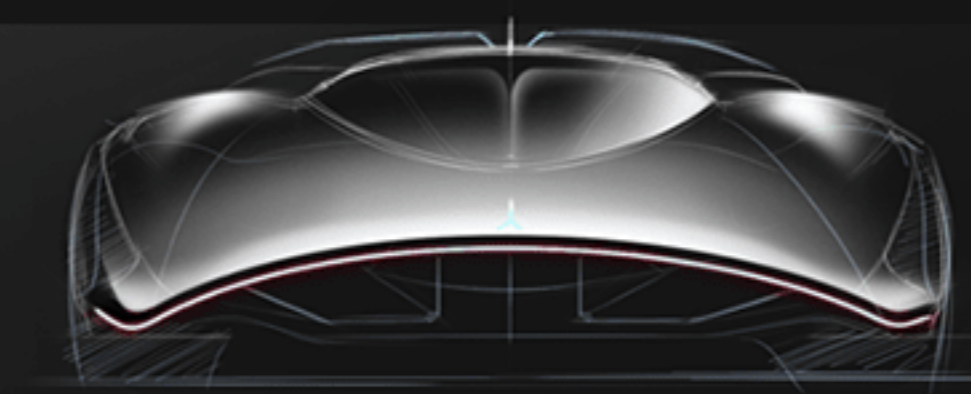
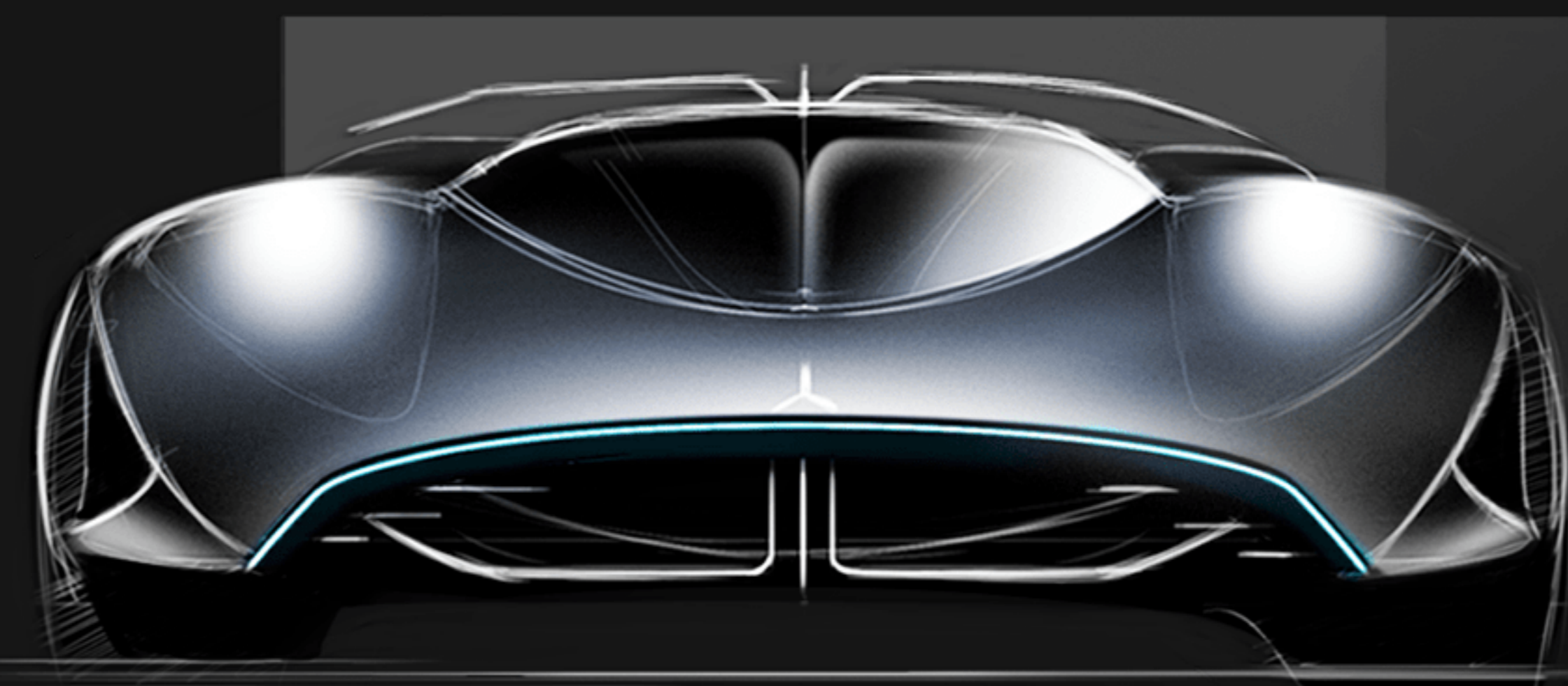

R EAR DESIGN STUDY

IN THE ERA OF ELECTRIC VEHICLE, GRILLE WILL HAVE MUCH LIMITED FUNCTION THAN BEFORE WHICH REQUIRE MORE MINIMAL, EFFICIENT AND DISTINCTIVE FRONT DESIGN

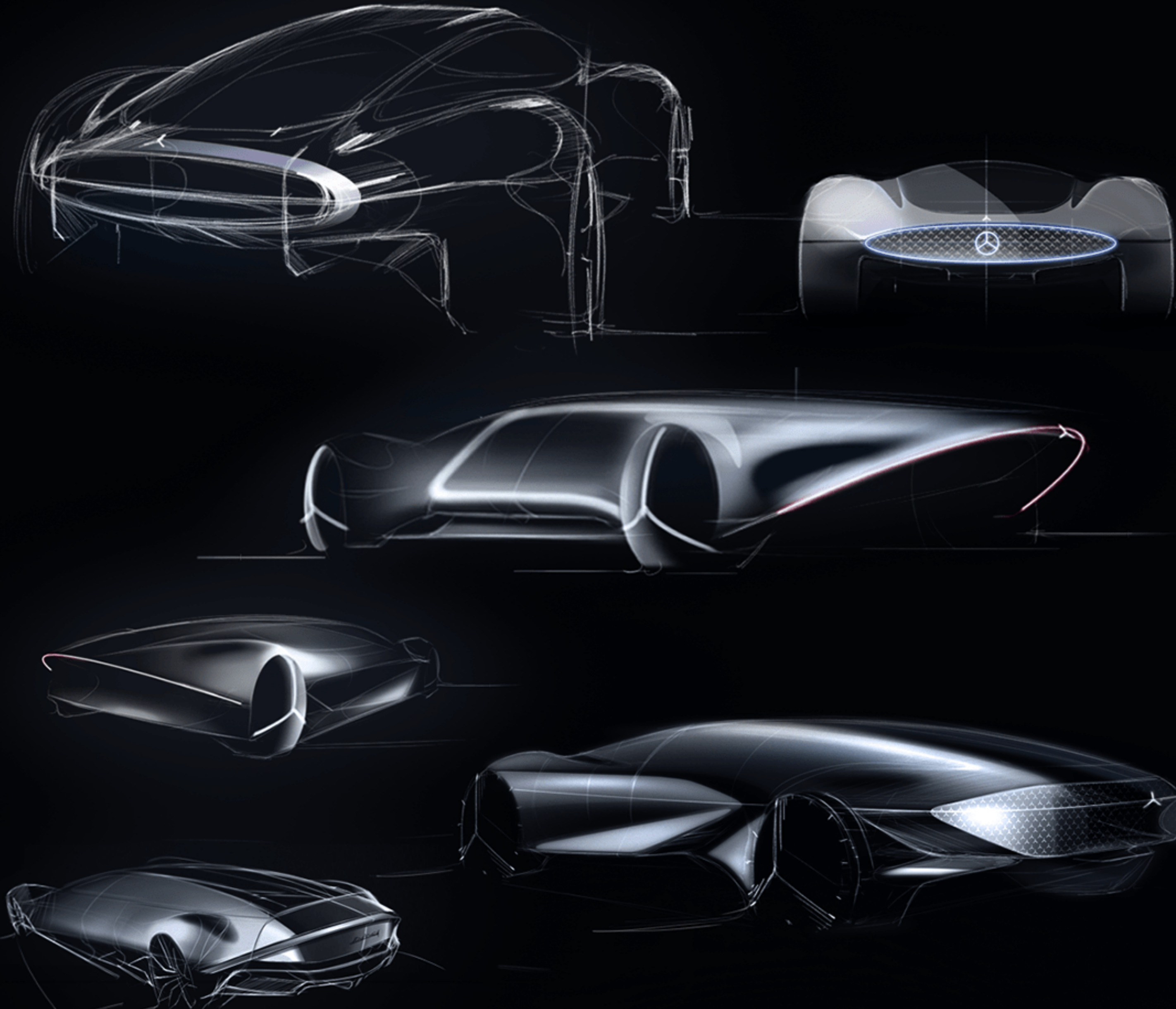

Layered theme

E LONGATED FENDER STUDY

IN ORDER TO HAVE A CLEAN, DYNAMIC AND OVERWHELMING FORM, I TRIED TO MAXIMIZE THE EXISTENCE OF EACH FENDER WITH MINIMUM CREASES

ELONGATED FENDERS HELP THIS VEHICLE LOOK EVEN SLEEKER AND LONGER WHICH LEAD TO MORE DYNAMIC AND SPORTY OVERALL FORM. PLUS, ENLONGATED FENDER VOLUME HELP THIS VEHICLE TO CREATE GREATER STANCE WHICH IS ESENTIAL TO LUXURY GT SEGMENT.

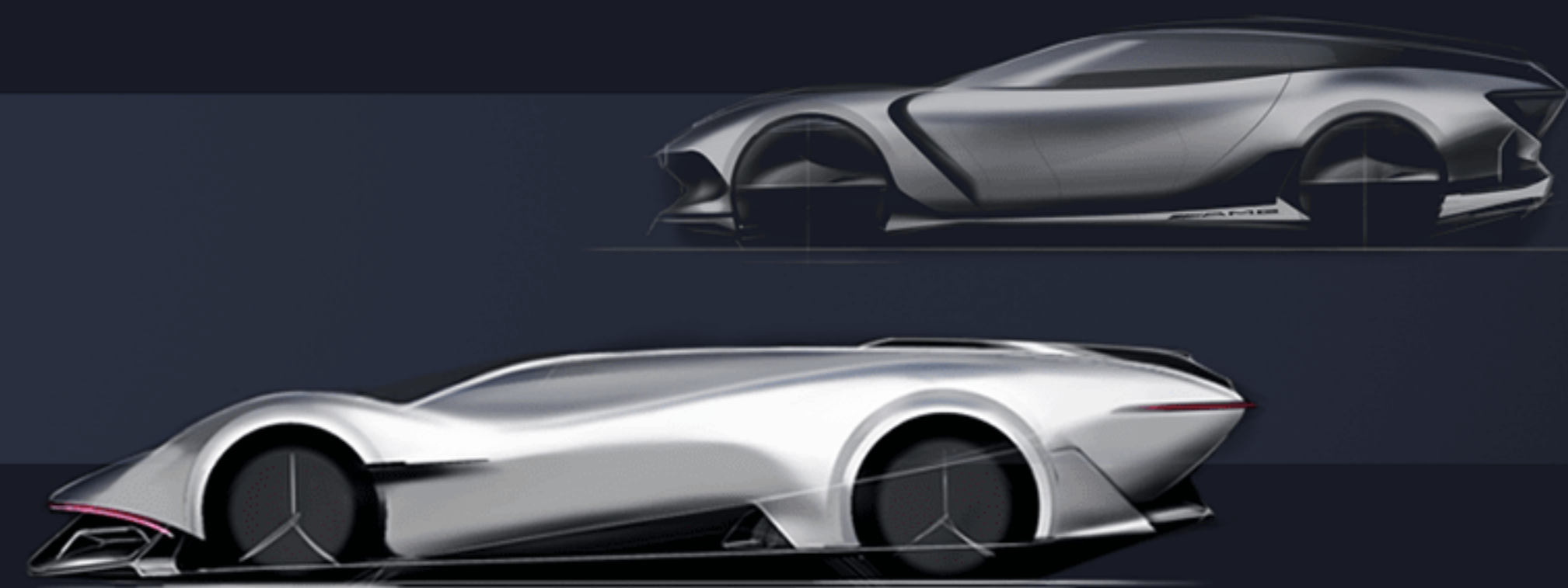
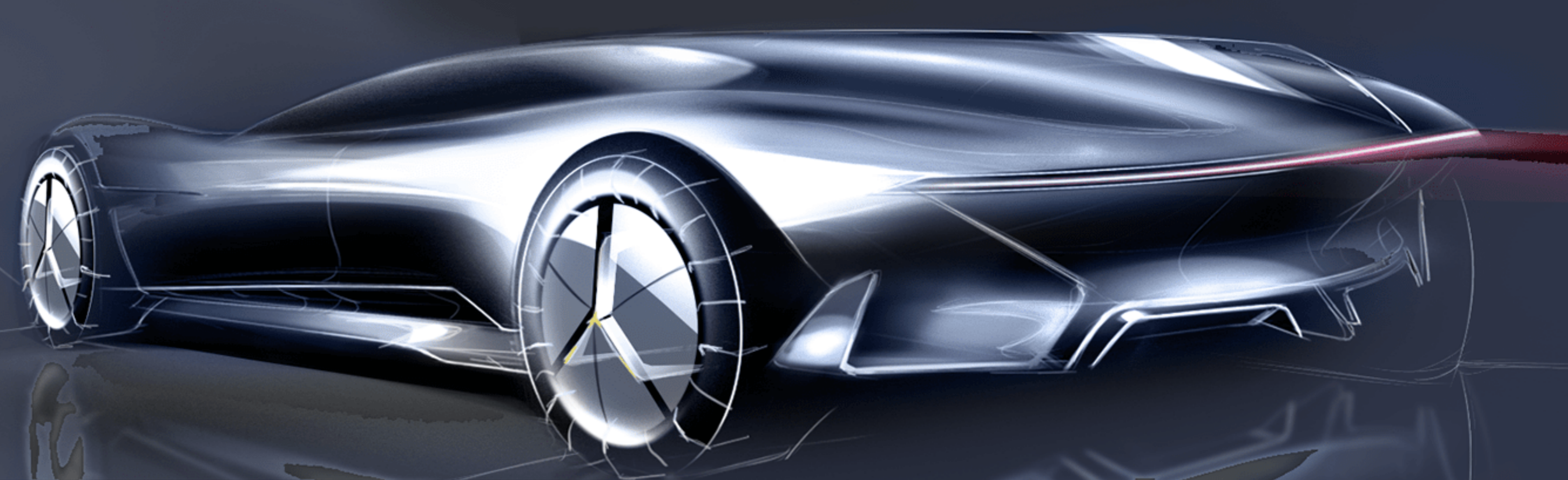
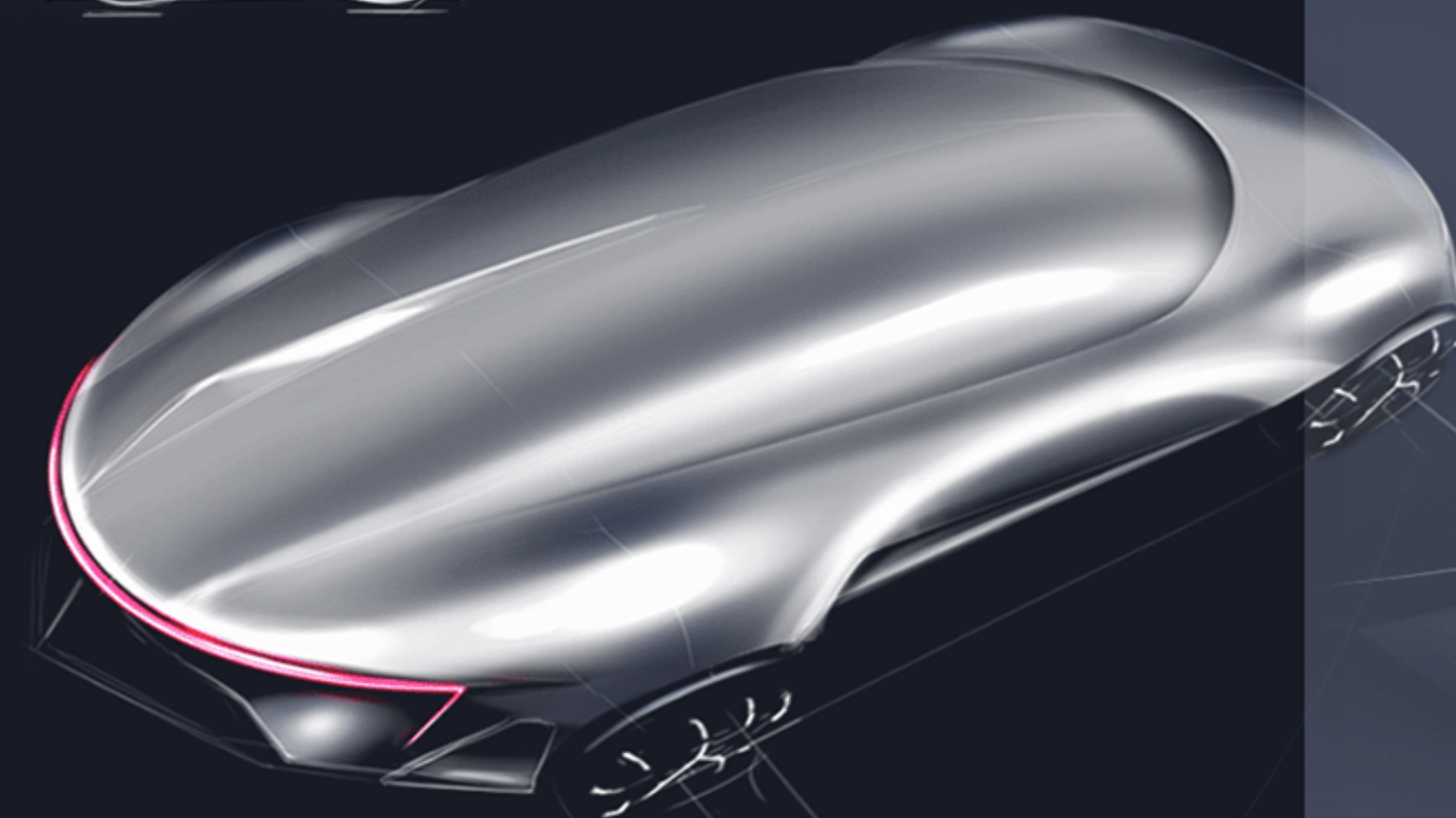
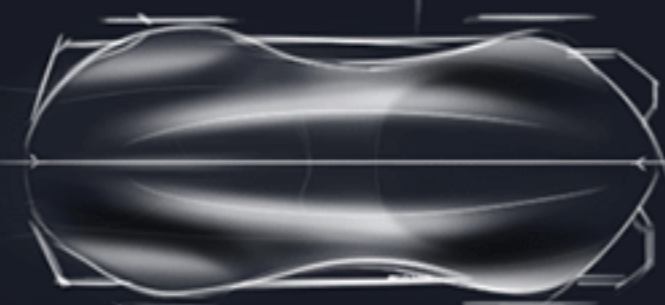
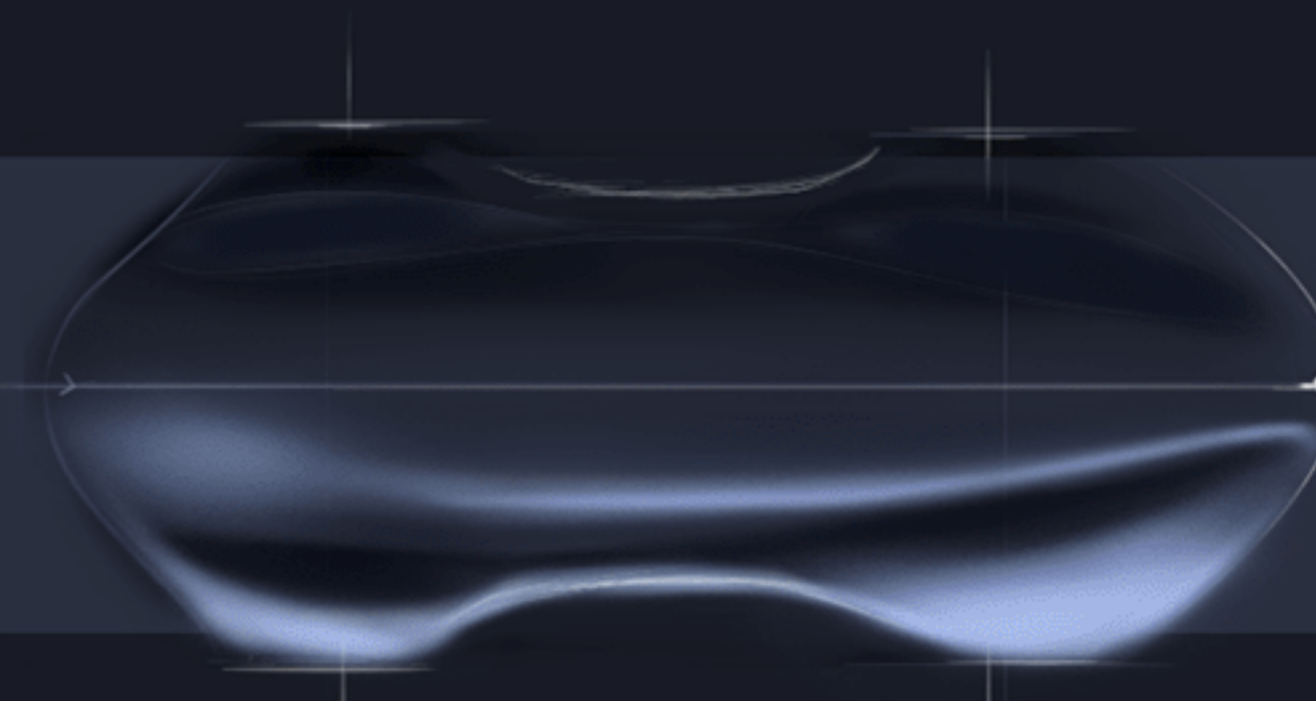
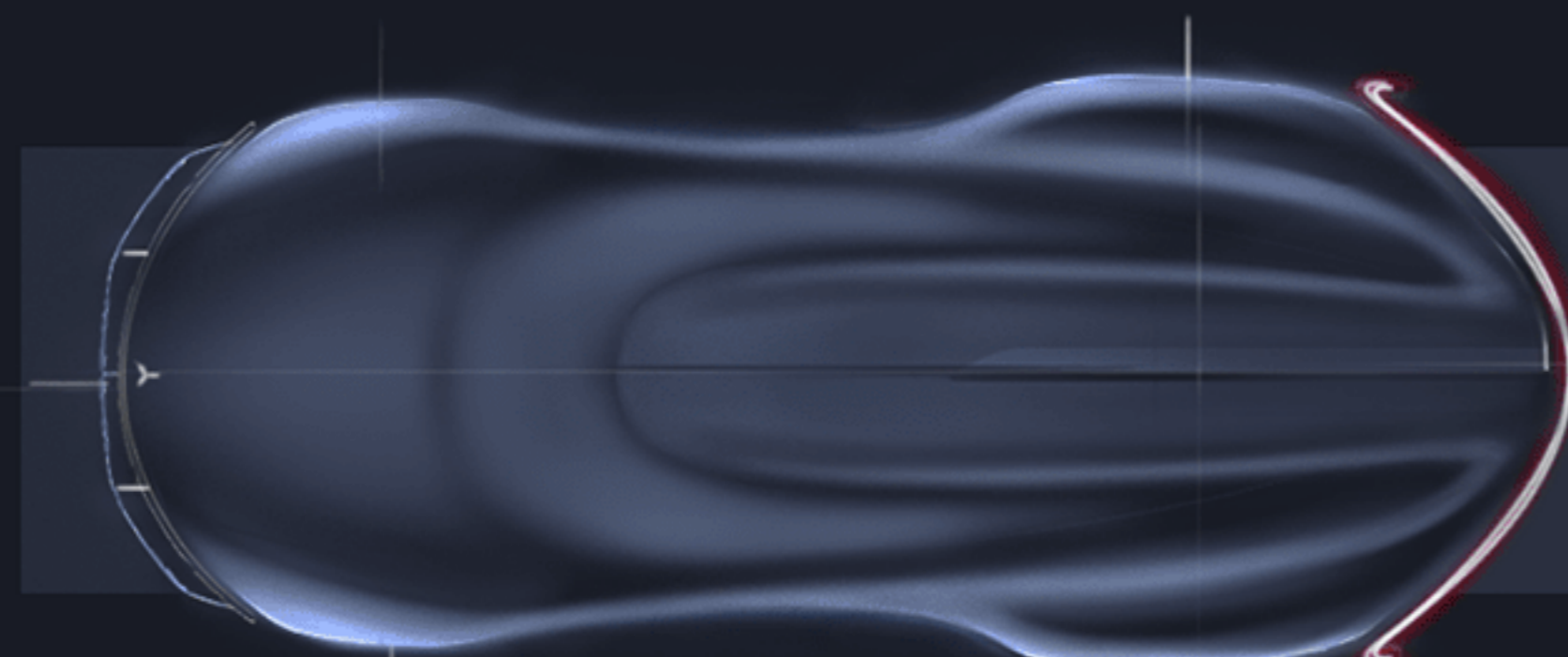
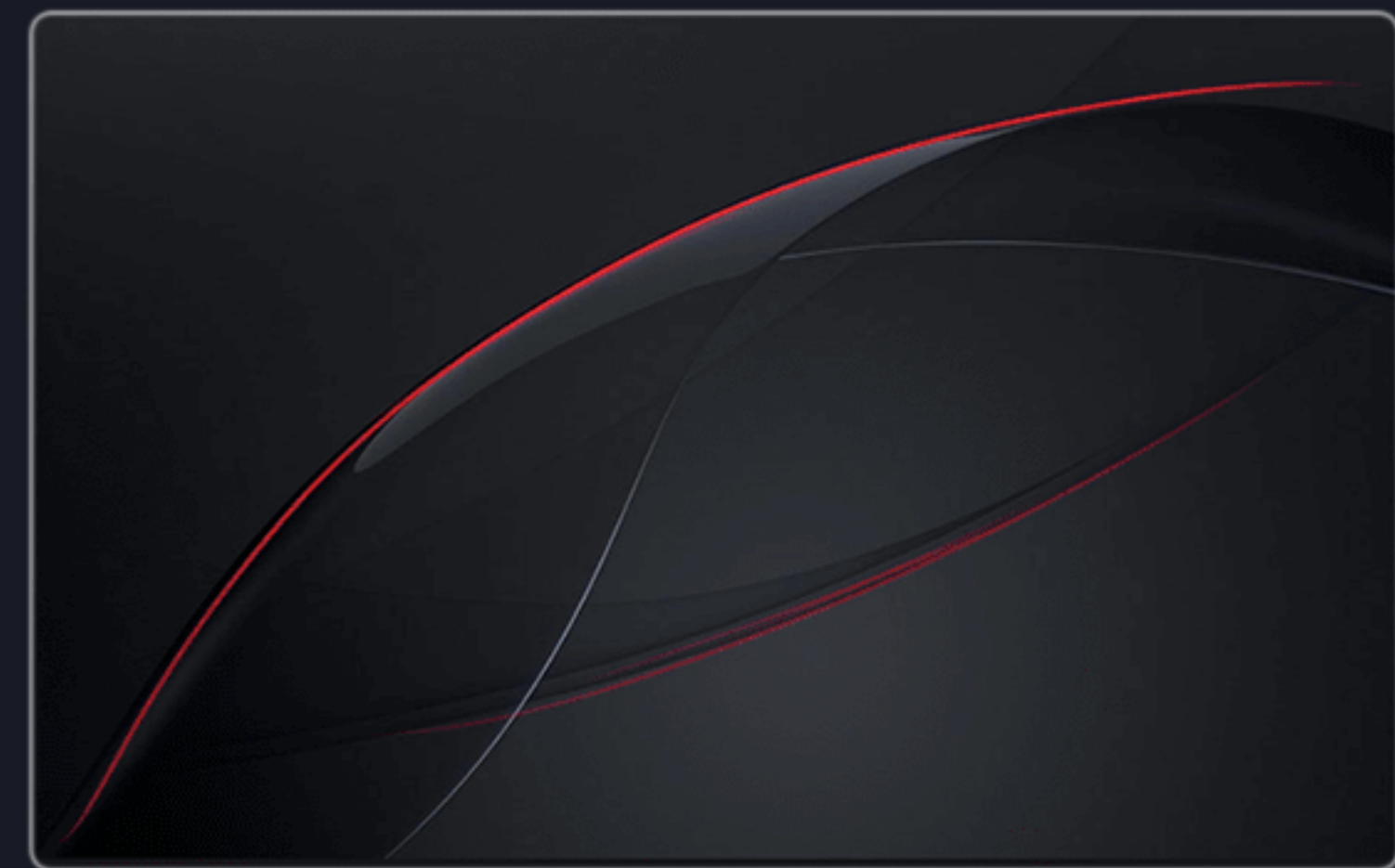

DEVELOPMENT

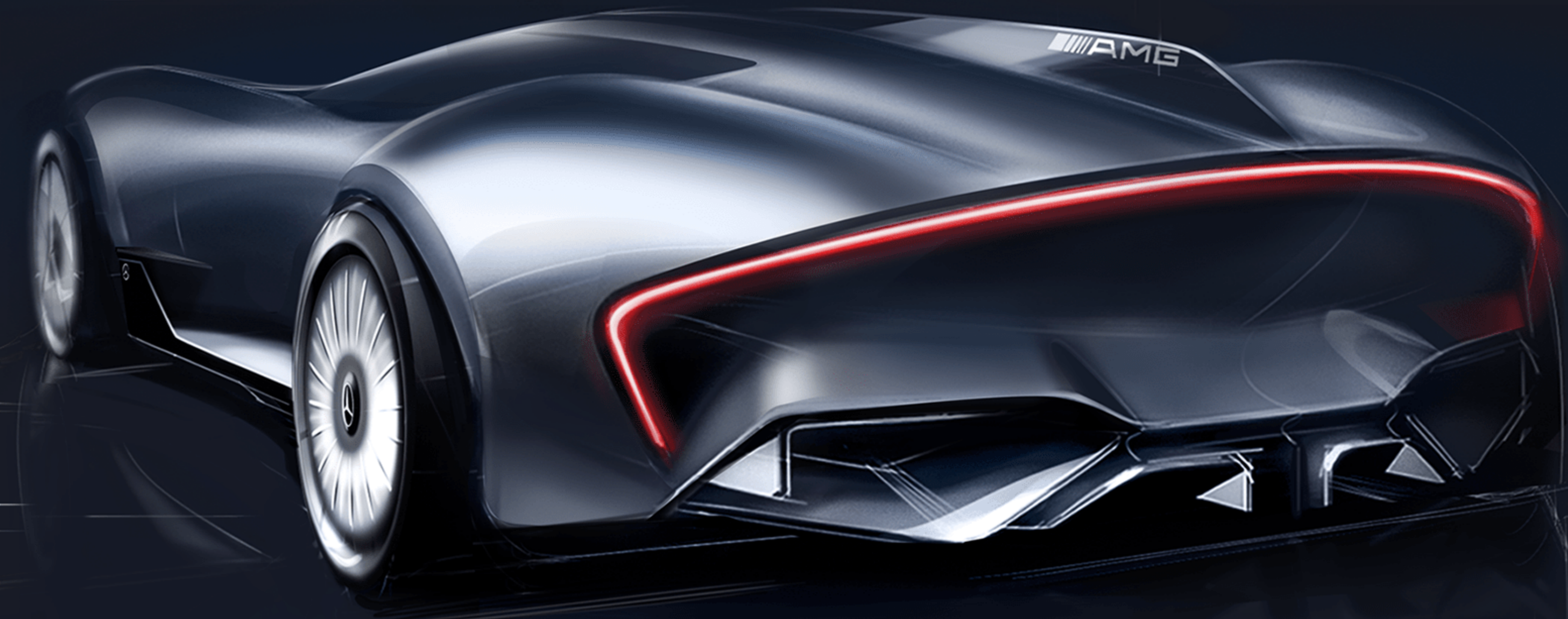
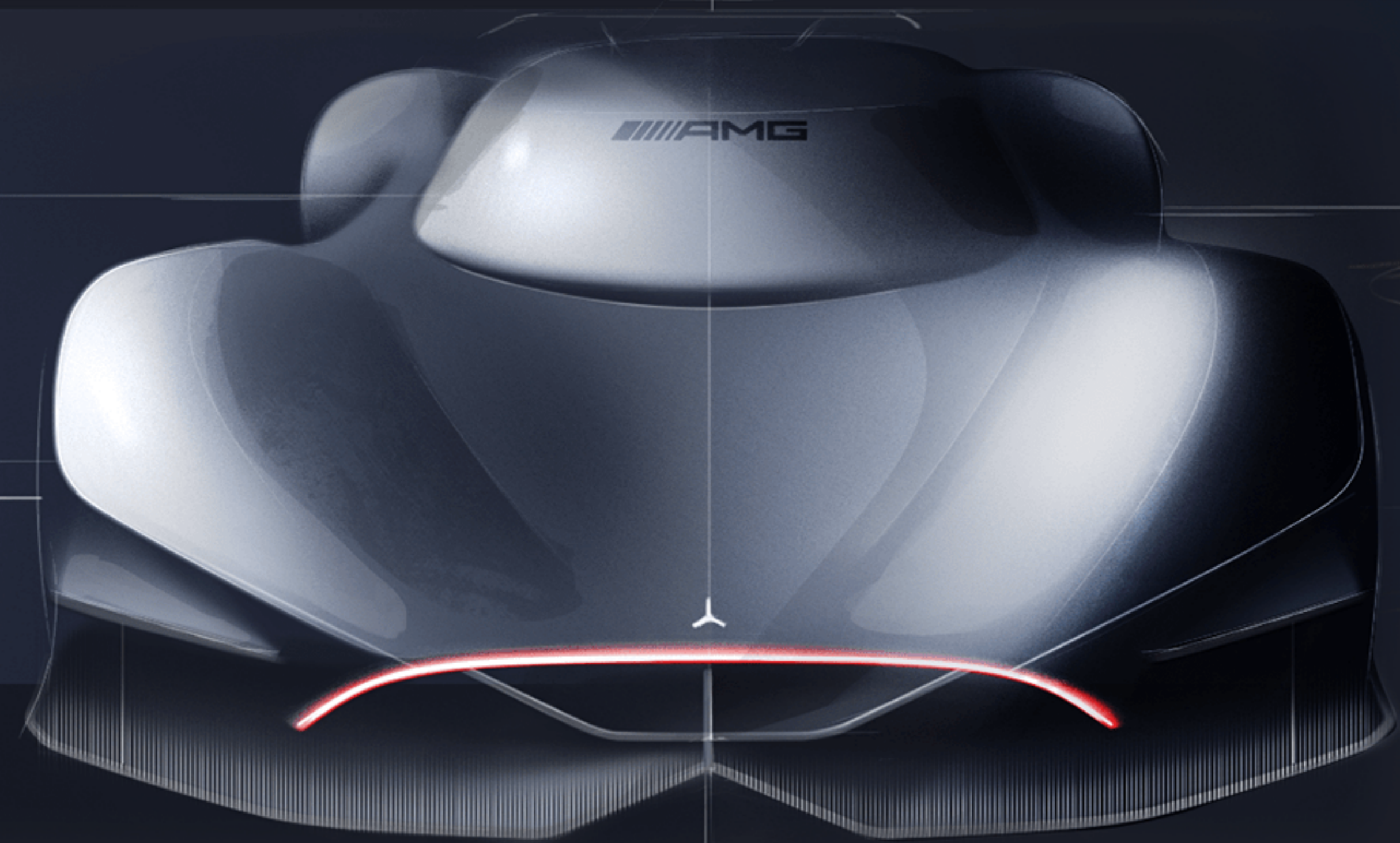
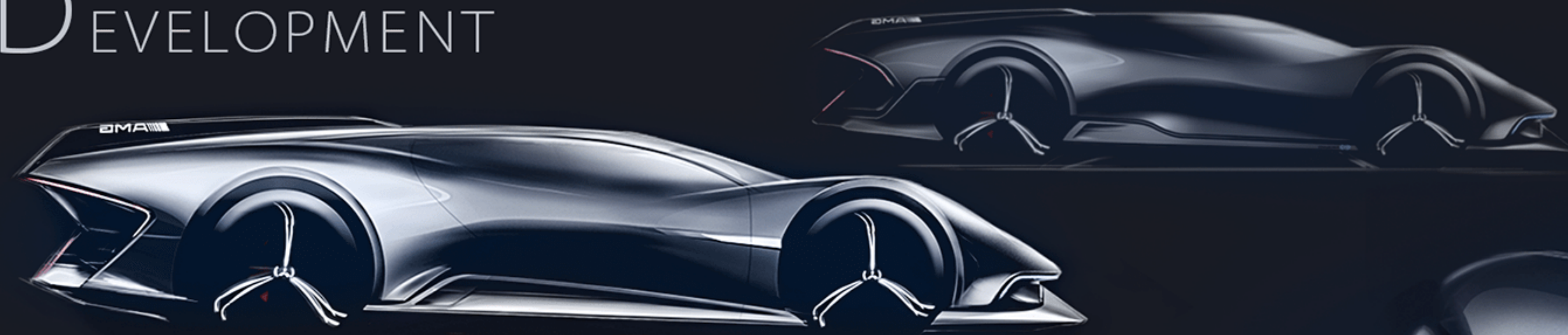

AMG



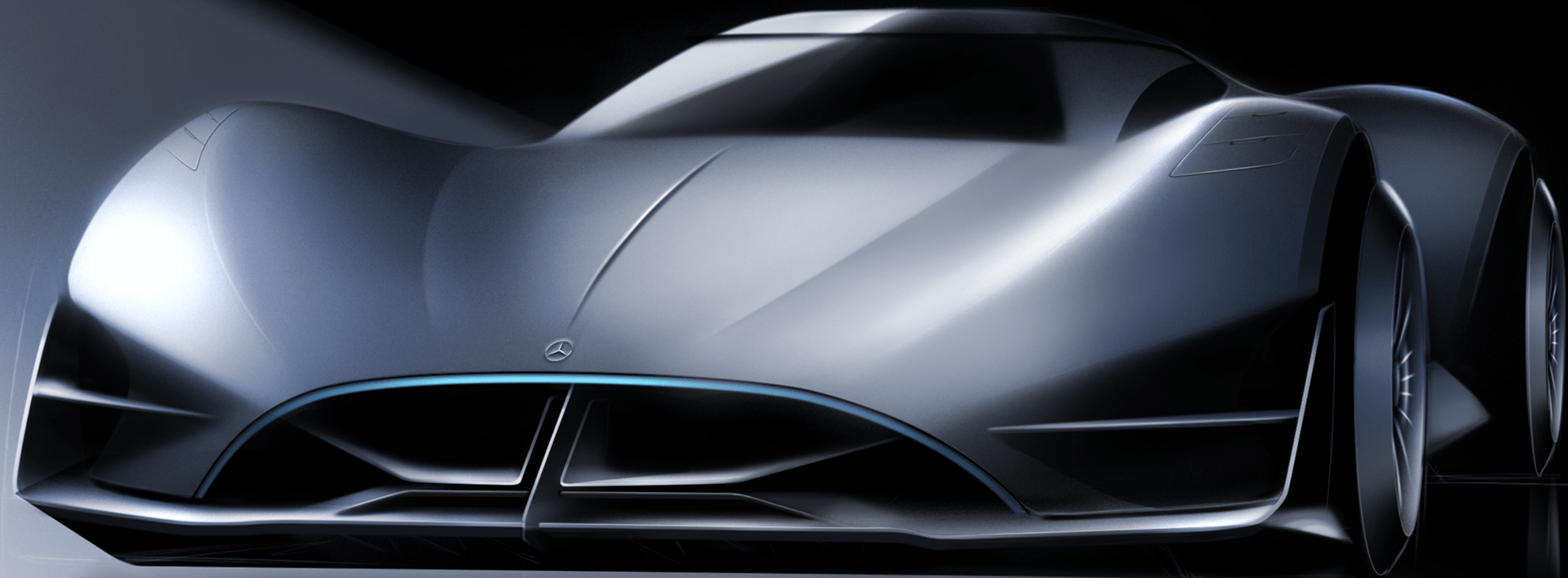



AMG

AMG

EC

AMG

PACKAGE

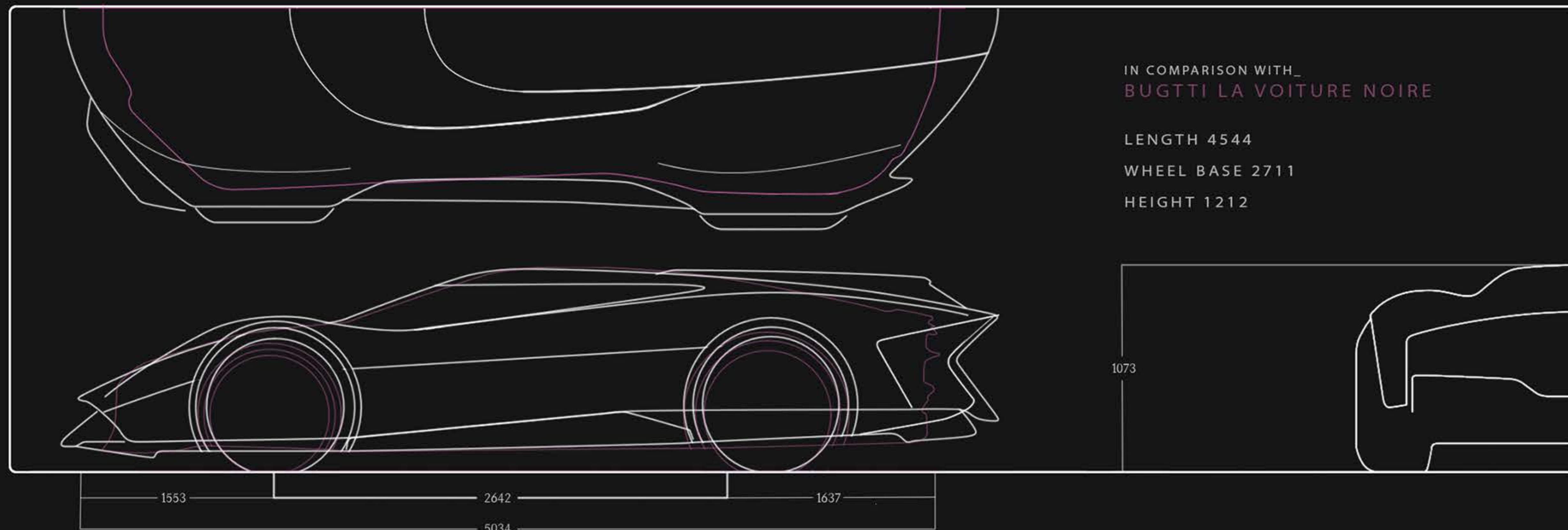

SUFFICIENT STORAGE ROOM

UNLIKE OTHER HYPER VEHICLES IN THE MARKET, AMG VISION GT PROVIDE AN INCOMPARABLE STORAGE ROOM FOR YOU JOURNEY THANKS TO THE ELECTRIC PLATFORM AND SHOOTING BRAKE FORM

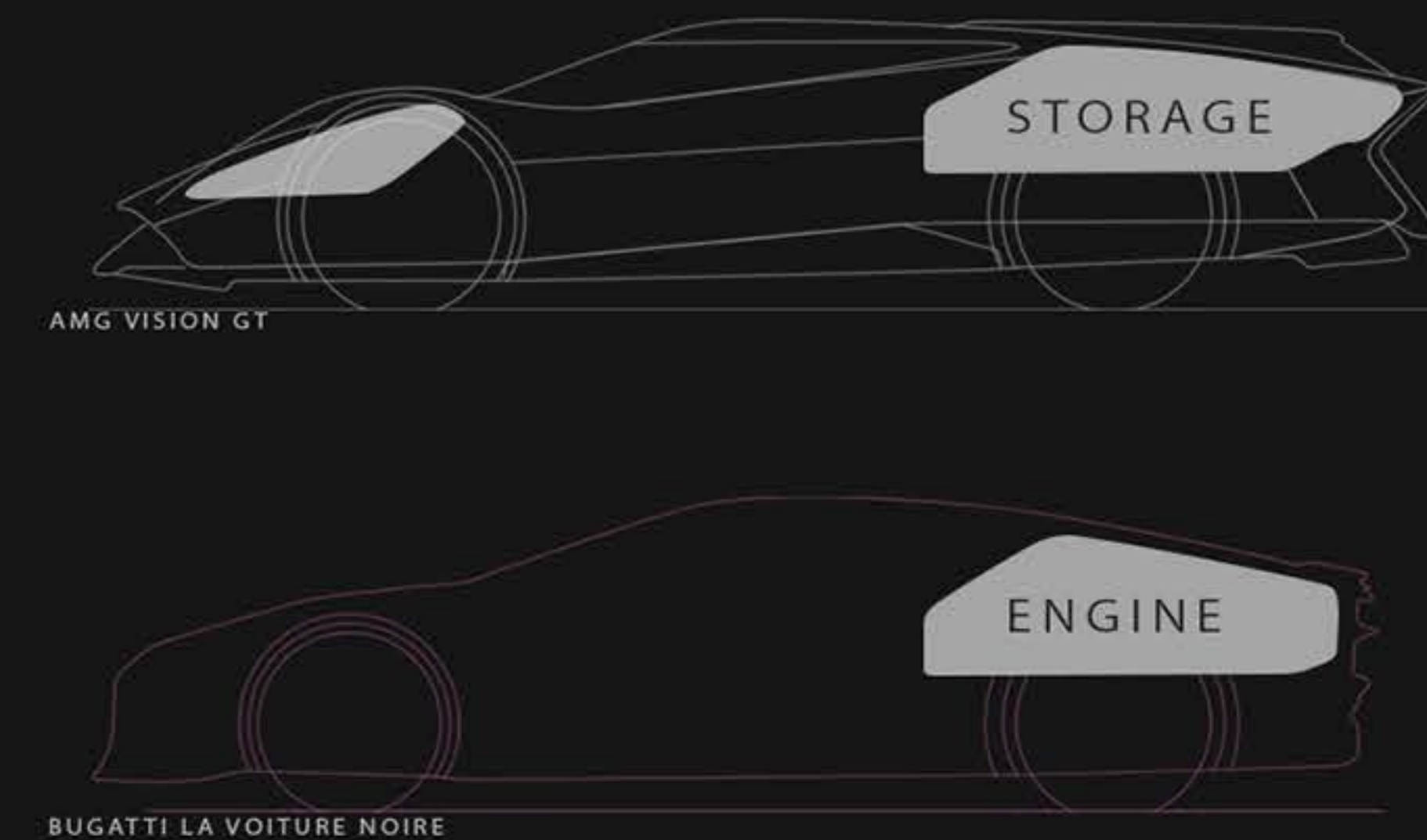

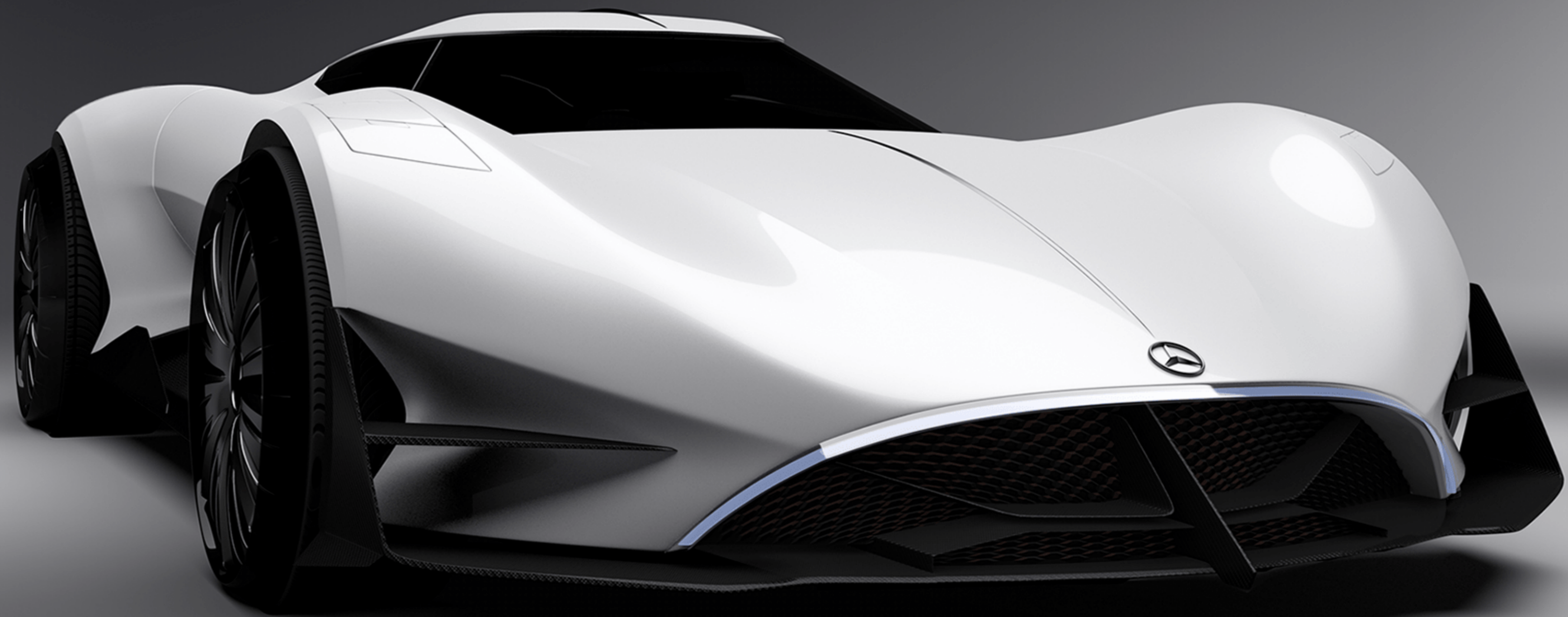



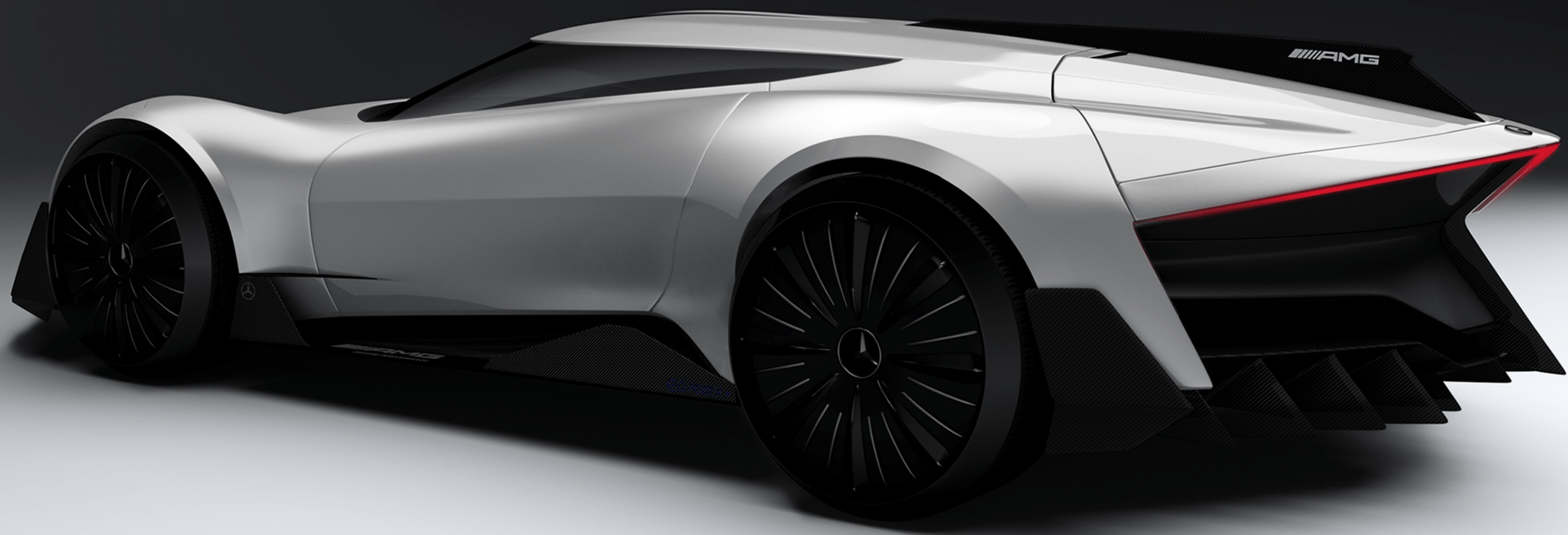











Sufficient Storage_

GT vehicle should be able to deal with your luggages no matter how many they are. Unlike most of hyper vehicles, AMG VISION GT has enough storage room for your journey thanks to the electric platform and shooting brake wagon form







MODEL - Alias Subdivision
RENDER - Vred